



# SACTO

Catalogo parti di ricambio  
Catalogue pièces détachées  
Spare parts catalogue  
Ersatzteilkatalog

Edizione aprile 2022



<b>DX-2</b> .....	<b>pag.</b>	<b>2</b>
<b>DX-3</b> .....		<b>4</b>
<b>DX-4</b> .....		<b>6</b>
<b>DX-5</b> .....		<b>8</b>
<b>DX-5 SM</b> .....		<b>10</b>
<b>SUPER 5</b> .....		<b>11</b>
<b>DX60</b> .....		<b>12</b>
<b>DX65</b> .....		<b>14</b>
<b>DX 8</b> .....		<b>16</b>
<b>DX 14</b> .....		<b>18</b>
<b>DX 14 AS</b> .....		<b>20</b>
<b>DX 16</b> .....		<b>22</b>
<b>DX 20</b> .....		<b>24</b>
<b>DX 30</b> .....		<b>26</b>
<b>NX 4</b> .....		<b>28</b>
<b>NX 5</b> .....		<b>30</b>
<b>NX 55</b> .....		<b>32</b>
<b>NX 65</b> .....		<b>34</b>
<b>NX 70</b> .....		<b>36</b>
<b>NX 36</b> .....		<b>38</b>
<b>NX 40 S</b> .....		<b>40</b>
<b>NX 40 new</b> .....		<b>42</b>
<b>NX 41</b> .....		<b>44</b>
<b>DX 45BAT</b> .....		<b>46</b>
<b>DX 75BAT</b> .....		<b>48</b>
<b>NX 90BAT</b> .....		<b>50</b>



PESO - WEIGHT - GEWICHT	kg 0,550
LUNGHEZZA - LENGHT - GESAMTLANGE	mm 260

RIVETTI BLIND RIVETS BLINDNIETEN	ALLUMINIO ALUMINIUM ALUMINIUM	ACCIAIO STEEL STAHL	RAME COPPER KUPPER	INOX INOX INOX
2,4	•			
3,0 - 3,2	•	•	•	•
4,0	•	•	•	•
4,8	•			

POS.	COD.	QT.	DESCRIZIONE	DENOMINATION	PARTS LIST	BEZEICHNUNG	€ cad.
1	10003/2	1	Set morsetti (2 pcs)	Mâchoires	Jaws	Klemmbacken	12,60
2	10006	1	Perno	Axe	Pin	Stift	1,20
3	10011	1	Ugello Ø 4	Embout	Nosepiece	Mundstück	2,60
4	10012	1	Ugello Ø 3,2	Embout	Nosepiece	Mundstück	2,60
5	10013	1	Ugello Ø 2,4	Embout	Nosepiece	Mundstück	2,60
6	10010	1	Ugello Ø 5	Embout	Nosepiece	Mundstück	2,60
7	10016	1	Cono portamorsetti	Tête	Jaw case	Backengehäuse	3,40
8	10020	1	Leva superiore	Bras	Handle	Hebelgriff	3,80
9	10323	1	Coppia impugnatura	Poignée	Handle grip	Griff	2,80
10	10142	1	Apri morsetti	Poussoir	Jaw pusher	Druckteller	0,90
11	10023	1	Molla premente	Ressort	Spring	Feder	0,30
12	10025	1	Chiave	Clè	Spanner	Schlüssel	0,80
13	10026	1	Molla torsione	Ressort	Spring	Feder	1,40
14	10027	1	Spina elastica	Goupille	Spring pin	Spannhülse	0,80
15	10028	1	Perno	Axe	Pin	Bolzen	0,80
16	10029	1	Rondella	Circlips	E-ring	Federring	0,40
17	10032	1	Leva inferiore	Corps	Pliers body	Zangenschaft	9,20
18	10036	1	Gancio	U de blocage	Stop spring	Schlussbügel	1,00

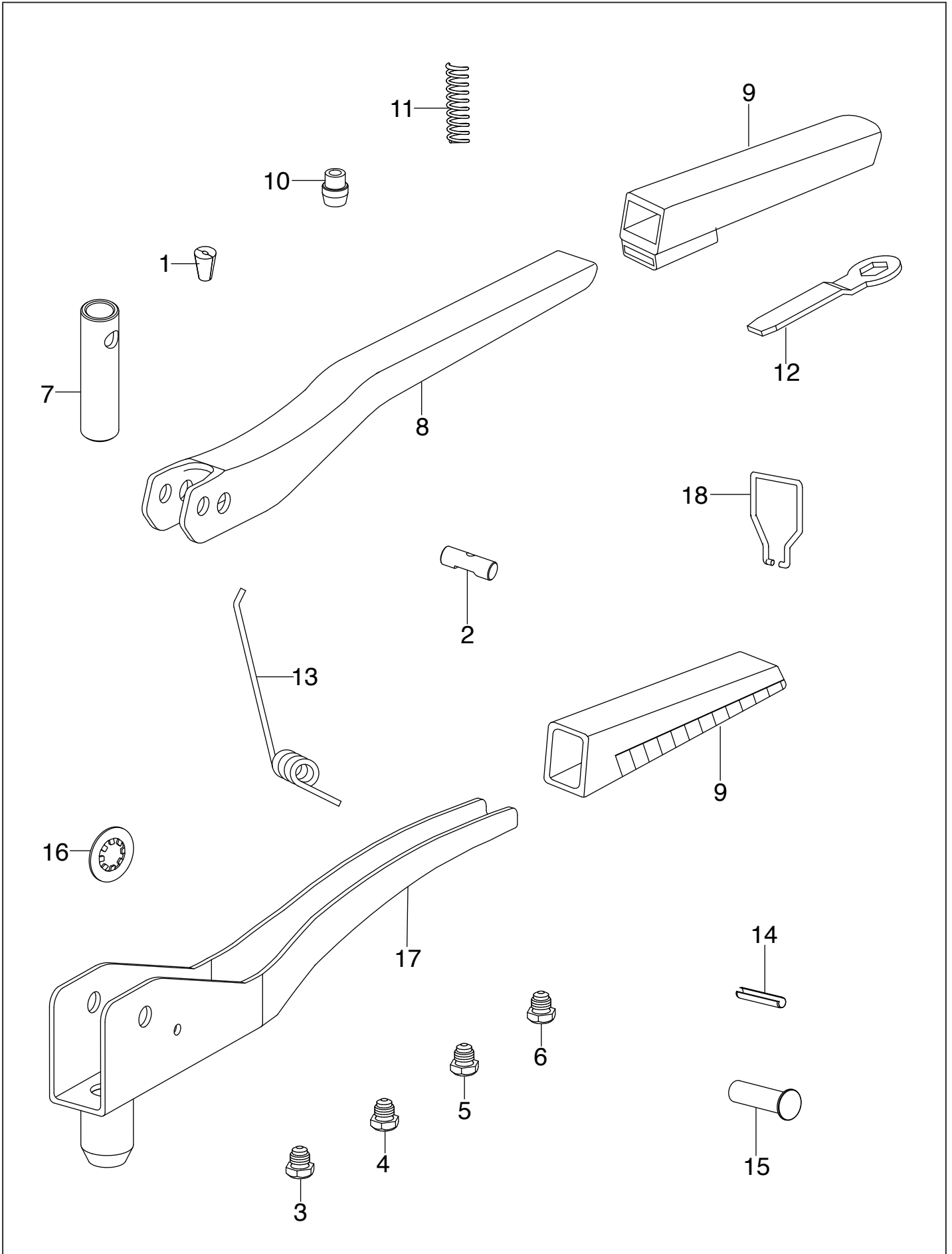



PESO - WEIGHT - GEWICHT	kg 0,500
LUNGHEZZA - LENGHT - GESAMTLANGE	mm 200

RIVETTI BLIND RIVETS BLINDNIETEN	ALLUMINIO ALUMINIUM ALUMINIUM	ACCIAIO STEEL STAHL	RAME COPPER KUPPER	INOX INOX INOX
2,4	•			
3,0 - 3,2	•	•	•	•
4,0	•	•	•	•
4,8	•			

POS.	COD.	QT.	DESCRIZIONE	DENOMINATION	PARTS LIST	BEZEICHNUNG	€ cad.
1	X3101	1	Chiusura	Fermeture	Locating ring	Stecker	1,20
2	X3102	1	Pistone	Piston	Piston	Kolben	5,00
3	X3103	1	Molla	Ressort	Spring	Feder	0,80
4	X3104	1	Apri morsetti	Ouvre-étaux	Jaw pusher	Druckteller	1,40
5	X3105	1	Set morsetti (3 pcs)	Etaux	Jaws	Klemmbacken	8,40
6	X3106	1	Cono	Cone	Jaw case	Zugteilkopf	2,40
7	X3107	1	Rondella inox	Rondelle	Washer	Scheibe	0,50
8	X3108	1	Ghiera di regolazione	Embout	Ring nut	Nut Mutter	2,50
9	X3109	1	Cannotto	Tête	Inner barrel	Innere Hülse	3,60
10	X3110	4	O-ring	O-ring	O-ring	O-ring	0,40
11	X3111	1	Ugello Ø 4,8	Embout Ø 4,8	Nosepiece Ø 4,8	Mundstück Ø 4,8	2,60
12	X3112	1	Ugello Ø 2,4	Embout Ø 2,4	Nosepiece Ø 2,4	Mundstück Ø 2,4	2,60
13	X3113	1	Ugello Ø 3,2	Embout Ø 3,2	Nosepiece Ø 3,2	Mundstück Ø 3,2	2,60
14	X3114	1	Ugello Ø 4,0	Embout Ø 4,0	Nosepiece Ø 4,0	Mundstück Ø 4,0	2,60
15	X3115	1	Leva superiore	Bras	Pliers lever	Hebelgriff	8,40
16	X3116	1	Impugnatura sup.	Poignée sup.	Handle grip	Griff	1,60
17	X3117	1	Gancio	Crochet	Hook	Haken	1,20
18	X3118	1	Impugnatura inf.	Poignée inf.	Handle grip	Griff	1,60
19	X3119	1	Corpo in alluminio	Corps alu	Pliers body	Zangenschaft	9,80
20	X3120	1	Dado	Écrou	Nut	Muttern	0,70
21	X3121	1	Molla torsione	Ressort	Spring	Feder	1,00
22	X3122	3	Perno	Axe	Pin rod	Bolzen	1,00
23	X3123	1	Vite	Vis	Screw	Schraub	0,80
24	X3124	1	Maglia	Maille	Link	Link	3,00
25	X3125	4	Vite	Vis	Screw	Schraub	0,80

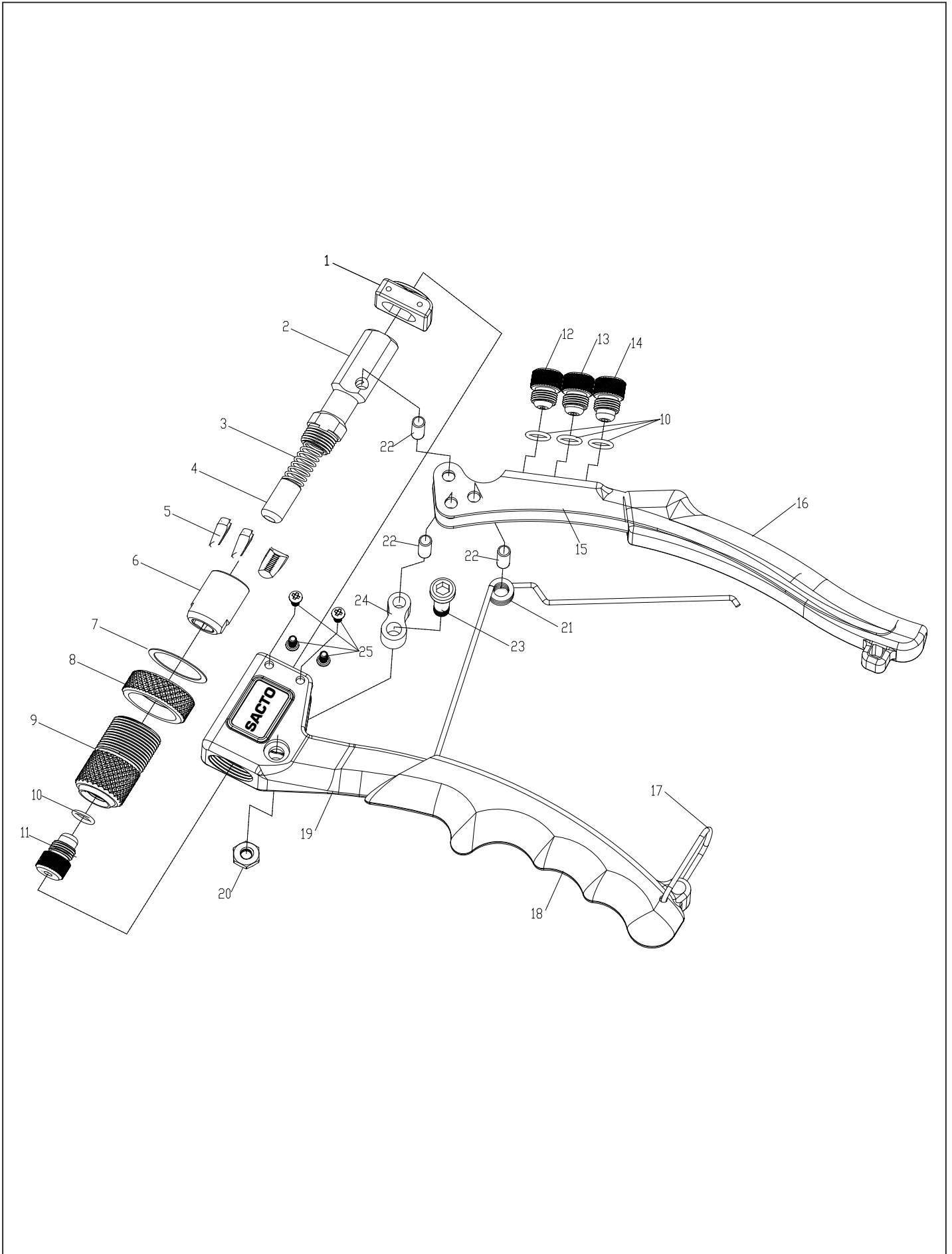



PESO - WEIGHT - GEWICHT	kg 0,520
LUNGHEZZA - LENGHT - GESAMTLANGE	mm 270

RIVETTI BLIND RIVETS BLINDNIETEN	ALLUMINIO ALUMINIUM ALUMINIUM	ACCIAIO STEEL STAHL	RAME COPPER KUPPER	INOX INOX INOX
2,4	•			
3,0 - 3,2	•	•	•	•
4,0	•	•	•	•
4,8	•			

POS.	COD.	QT.	DESCRIZIONE	DENOMINATION	PARTS LIST	BEZEICHNUNG	€ cad.
1	10003	1	Set morsetti (3 pcs)	Mâchoires	Jaws	Klemmbacken	12.60
2	10010	1	Ugello Ø 5	Embout	Nosepiece	Mundstück	2.60
3	10011	1	Ugello Ø 4	Embout	Nosepiece	Mundstück	2.60
4	10012	1	Ugello Ø 3,2	Embout	Nosepiece	Mundstück	2.60
5	10013	1	Ugello Ø 2,4	Embout	Nosepiece	Mundstück	2.60
6	10025	1	Chiave	Clè	Spanner	Schlüssel	0.80
7	10060	1	Perno Ø 6x30	Axe	Pin	Bolzen	1.20
8	10144	1	Apri morsetti	Poussoir	Jaw pusher	Druckteller	0.90
9	10068	1	Molla premente	Ressort	Spring	Feder	0.30
10	10071	1	Gancio	U de blocage	Stop spring	Schlussbügel	1.00
11	10076	1	Perno Ø 6x16	Axe	Pin	Bolzen	0.60
12	10114	1	Spina elastica	Goupille	Spring pin	Spannhülse	0.80
13	10232	1	Anello elastico	Circlips	Seeger ring	Seeger Ring	0.30
14	10310	1	Molla torsione	Ressort	Spring	Feder	1.40
15	10312	1	Leva superiore	Levier	Pliers lever	Hebelgriff	6.80
16	10313	1	Leva inferiore	Corps	Pliers body	Zangenschaft	14.60
17	10315	1	Coppia impugnatura	Poignée	Handle grip	Griff	2.80
18	10500	1	Cono portapinze	Tête	Jaw case	Backengehäuse	4.20
19	10070	1	Cannotto	Douille	Barrel	Hülse	5.40

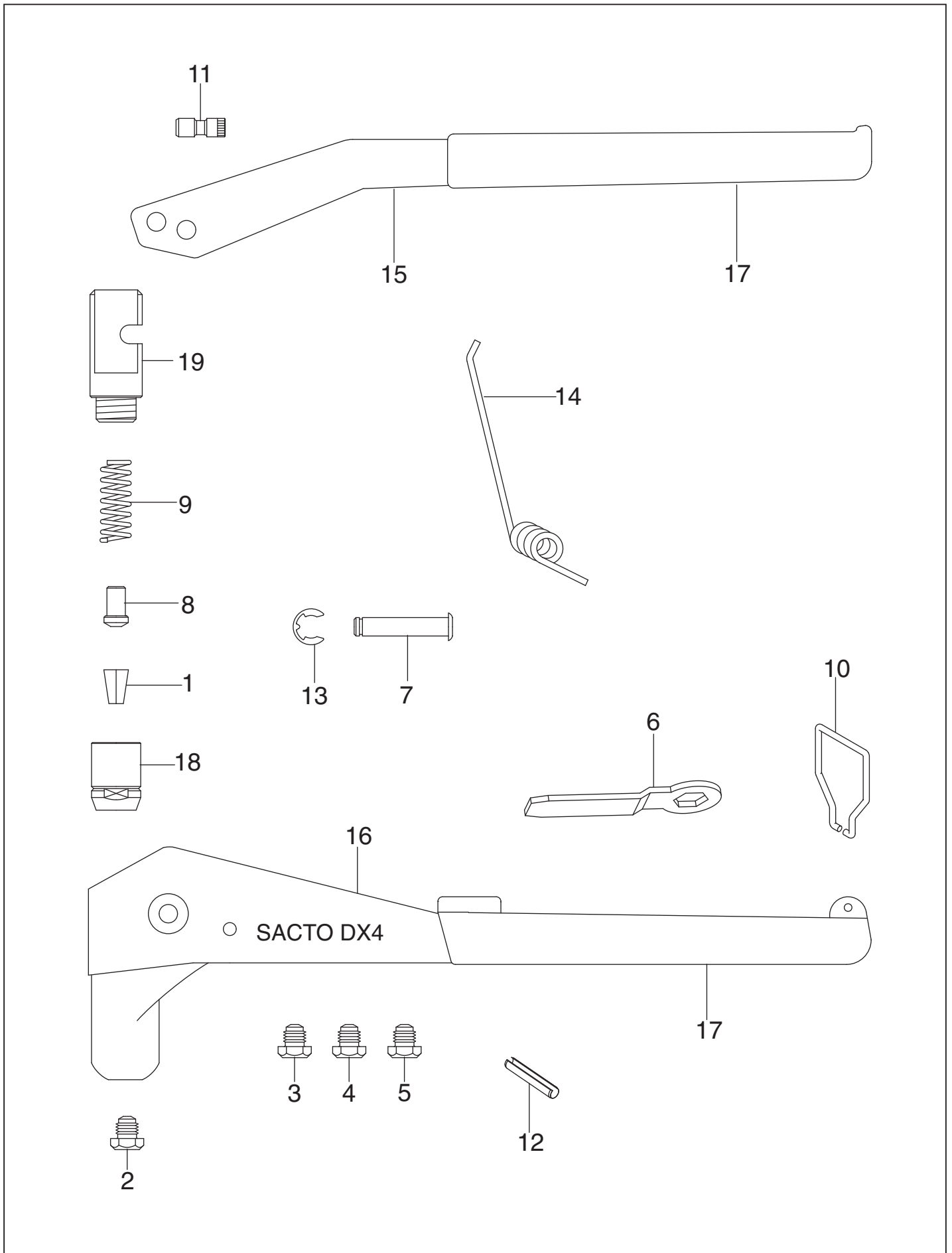



PESO - WEIGHT - GEWICHT	kg 0,540
LUNGHEZZA - LENGHT - GESAMTLANGE	mm 250

RIVETTI BLIND RIVETS BLINDNIETEN	ALLUMINIO ALUMINIUM ALUMINIUM	ACCIAIO STEEL STAHL	RAME COPPER KUPFER	INOX INOX INOX
2,4	•			
3,0 - 3,2	•	•	•	•
4,0	•	•	•	•
4,8	•			

POS.	COD.	QT.	DESCRIZIONE	DENOMINATION	PARTS LIST	BEZEICHNUNG	€ cad.
1	10003	1	Set morsetti (3 pcs)	Set Mâchoires	Set Jaws	Set Klemmbacken	12.60
2	10010	1	Ugello Ø 5	Embout	Nosepiece	Mundstück	2.60
3	10011	1	Ugello Ø 4	Embout	Nosepiece	Mundstück	2.60
4	10012	1	Ugello Ø 3,2	Embout	Nosepiece	Mundstück	2.60
5	10013	1	Ugello Ø 2,4	Embout	Nosepiece	Mundstück	2.60
6	10021	1	Coppia impugnatura	Poignée	Handle grip	Griff	2.80
7	10024	1	Spina elastica 4x24	Goupille	Spring pin	Spannhülse	0.80
8	10025	1	Chiave	Clè	Spanner	Schlüssel	0.80
9	10036	1	Gancio	U de blocage	Stop spring	Schlussbügel	1.00
10	10047	1	Cannotto	Tirant	Inner barrel	Innere Hülse	5.40
11	10049	1	Cono	Tête de tirant	Jaw case	Zugteilkopf	4.20
12	10052	1	Leva inferiore	Corps	Pliers body	Zangenschaft	16.60
13	10055	1	Leva superiore	Bras	Pliers lever	Hebelgriff	7.20
14	10059	1	Perno Ø 6	Axe	Fulcrum pin	Bolzen	0.60
15	10144	1	Apri morsetti	Poussoir	Jaw pusher	Druckteller	0.90
16	10068	1	Molla premente	Ressort	Spring	Feder	0.30
17	10069	1	Molla torsione	Ressort	Spring	Feder	1.40
18	10076	1	Perno Ø 6	Axe	Pin	Bolzen	1.20





**SENZA MOLLA DI RITORNO  
WITHOUT SPRING**

PESO - WEIGHT - GEWICHT	kg 0,500
LUNGHEZZA - LENGHT - GESAMTLANGE	mm 250

RIVETTI BLIND RIVETS BLINDNIETEN	ALLUMINIO ALUMINIUM	ACCIAIO STEEL STAHL	RAME COPPER KUPPER	INOX INOX
2,4	•			
3,0 - 3,2	•	•	•	•
4,0	•	•	•	•
4,8	•			

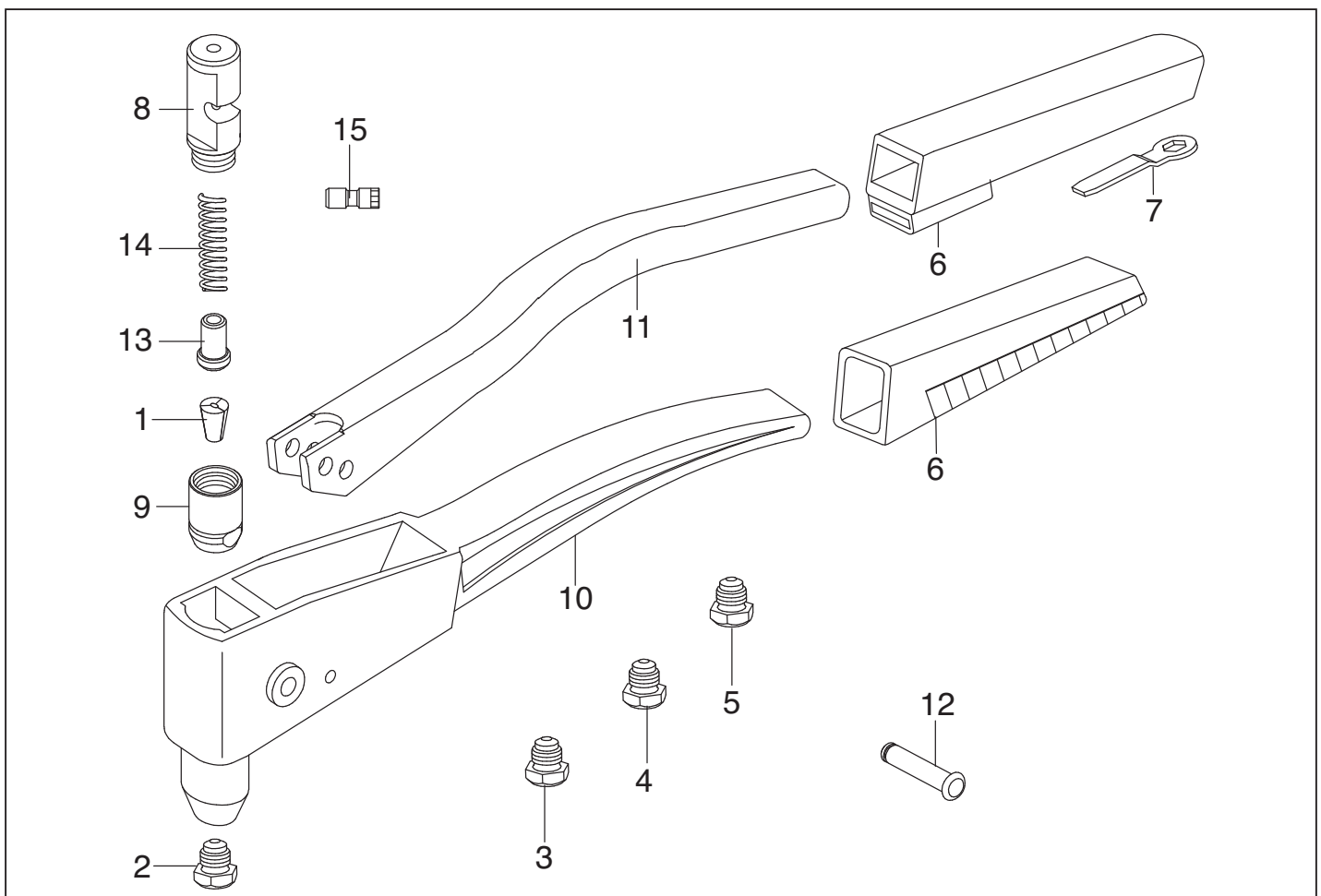
POS.	COD.	QT.	DESCRIZIONE	DENOMINATION	PARTS LIST	BEZEICHNUNG	€ cad.
1	10003	1	Set morsetti (3 pcs)	Set Mâchoires	Set Jaws	Set Klemmbacken	12.60
2	10010	1	Ugello Ø 5	Embout	Nosepiece	Mundstück	2.60
3	10011	1	Ugello Ø 4	Embout	Nosepiece	Mundstück	2.60
4	10012	1	Ugello Ø 3,2	Embout	Nosepiece	Mundstück	2.60
5	10013	1	Ugello Ø 2,4	Embout	Nosepiece	Mundstück	2.60
6	10222	1	Coppia impugnatura	Poignée	Handle grip	Griff	2.80
7	10025	1	Chiave	Clè	Spanner	Schlüssel	0.80
8	10047	1	Cannotto	Tirant	Inner barrel	Innere Hülse	5.40
9	10049	1	Cono	Tête de tirant	Jaw case	Zugteilkopf	4.20
10	10052	1	Leva inferiore	Corps	Pliers body	Zangenschaft	16.60
11	10055	1	Leva superiore	Bras	Pliers lever	Hebelgriff	7.20
12	10059	1	Perno Ø 6	Axe	Fulcrum pin	Bolzen	0.60
13	10144	1	Apri morsetti	Poussoir	Jaw pusher	Druckteller	0.90
14	10068	1	Molla premente	Ressort	Spring	Feder	0.30
15	10076	1	Perno Ø 6	Axe	Pin	Bolzen	0.60





PESO - WEIGHT - GEWICHT	kg 0,800
LUNGHEZZA - LENGHT - GESAMTLANGE	mm 340

RIVETTI BLIND RIVETS BLINDNIETEN	ALLUMINIO ALUMINIUM ALUMINIUM	ACCIAIO STEEL STAHL	RAME COPPER KUPPER	INOX INOX INOX
3,0 - 3,2	•	•	•	•
4,0	•	•	•	•
4,8	•	•	•	•

POS.	COD.	QT.	DESCRIZIONE	DENOMINATION	PARTS LIST	BEZEICHNUNG	€ cad.
1	10056	1	Ugello Ø 5 alu.	Embout Ø 5	Nosepiece Ø 5	Mundstück Ø 5	2.60
2	10085	1	Ugello Ø 5 acciaio	Embout Ø 5	Nosepiece Ø 5	Mundstück Ø 5	2.60
3	10086	1	Ugello Ø 4	Embout Ø 4	Nosepiece Ø 4	Mundstück Ø 4	2.60
4	10087	1	Ugello Ø 3,2	Embout Ø 3,2	Nosepiece Ø 3,2	Mundstück Ø 3,2	2.60
5	10075	1	Coppia impugnatura	Poignée	Handle Grip	Griff	2.70
6	10079	1	Perno	Axe	Pin	Bolzen	1.70
7	10137	1	Cono portamorsetti	Tête de tirant	Jaw case	Backengehause	8.00
8	10081	1	Set morsetti (3 pcs)	Mâchoires	Jaws	Klemmbacken	18.60
9	10084	1	Leva superiore	Bras	Handle	Hebelgriff	8.60
10	10089	1	Leva inferiore RAL 3000	Corps	Pliers Body	Zangenschaft	25.00
11	10130	1	Cannotto	Tirant	Inner barrel	Innere Hülse	10.00
12	10186	1	Perno	Axe	Pin	Bolzen	1.60
13	10314	1	Molla premente	Ressort	Spring	Feder	0.60
14	10037	1	Apri morsetti	Poussoir	Jaw Pusher	Druckteller	2.60
15	10587	1	Seeger anello elastico Ø 6	Circlips	Seeger Ring	Seeger Ring	0.90

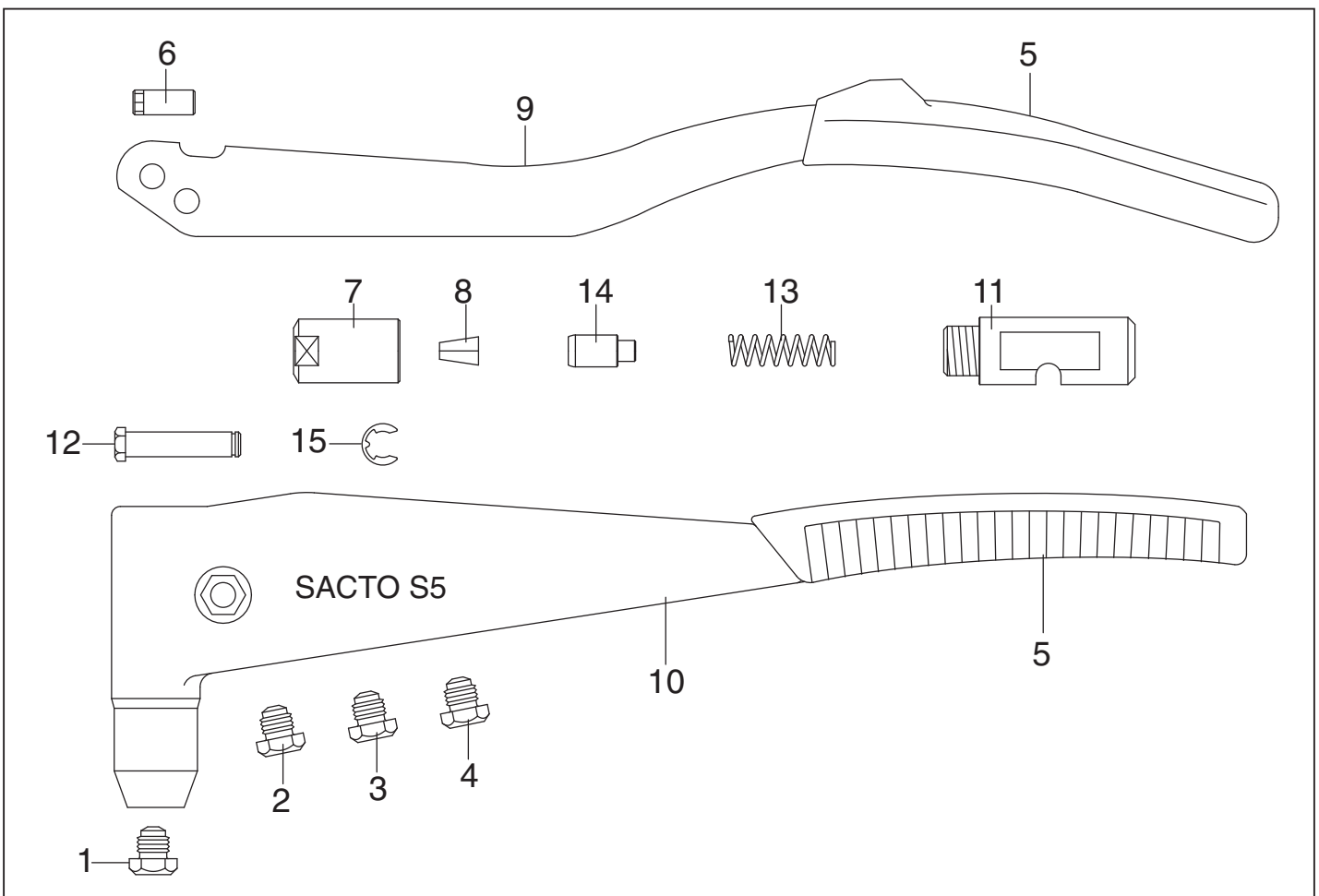



PESO - WEIGHT - GEWICHT	kg 0,600
LUNGHEZZA - LENGHT - GESAMTLANGE	mm 280

RIVETTI BLIND RIVETS BLINDNIETEN	ALLUMINIO ALUMINIUM ALUMINIUM	ACCIAIO STEEL STAHL	RAME COPPER KUPPER	INOX INOX
2,4	•	•	•	•
3,0 - 3,2	•	•	•	•
4,0	•	•	•	•
4,8	•	•	•	•

POS.	COD.	QT.	DESCRIZIONE	DENOMINATION	PARTS LIST	BEZEICHNUNG	€ cad.
1	SA0048	1	Ugello Ø 4,8	Embout Ø 4,8	Nosepiece Ø 4,8	Mundstück Ø 4,8	2,60
2	SA0103	1	Cannotto	Tête	Inner barrel	Innere Hülse	8,00
3	SA0158	1	Ghiera di regolazione	Embout	Ring nut	Nut Mutter	4,50
4	SA0011	1	Cono	Cone	Jaw case	Zugteilkopf	6,00
5	SA0053	3	Morsetti	Etaux	Jaws	Klemmbacken	1,80
6	SA0054	1	Apri morsetti	Poussoir	Jaw pusher	Druckteller	1,70
7	SA0113	1	Molla premente	Ressort	Spring	Feder	1,00
8	SA0102	1	Pistone	Piston	Piston	Kolben	8,20
9	SA0127	2	Impugnatura	Poignée	Handle grip	Griff	6,00
10	SA0077	2	Coppia leve	Bras	Pliers lever	Hebelgriff	9,00
11	SA0024	1	Ugello Ø 2,4	Embout Ø 2,4	Nosepiece Ø 2,4	Mundstück Ø 2,4	2,60
12	SA0032	1	Ugello Ø 3,2	Embout Ø 3,2	Nosepiece Ø 3,2	Mundstück Ø3,2	2,60
13	SA0040	1	Ugello Ø 4,0	Embout Ø 4,0	Nosepiece Ø 4,0	Mundstück Ø 4,0	2,60
14	SA0048	1	Ugello Ø 4,8	Embout Ø 4,8	Nosepiece Ø 4,8	Mundstück Ø 4,8	2,60
15	SA0101	1	Corpo	Corp	Body	Gehäuse	12,60
16	SA0087	4	Vite	Vis	Screw	Schraub	0,80
17	SA0067	4	Distanziale	Rondelle	Washer	Scheibe	0,70
18	SA0099	4	Rondella	Rondelle	Washer	Scheibe	0,50
19	SA0086	4	Dado	Écrou	Nut	Muttern	0,80
20	SA0114	2	Perno	Axe	Pin rod	Bolzen	0,60
21	SA0084	8	Rondella	Rondelle	Washer	Scheibe	0,50
22	SA0104	4	Leve piccole	Biellette	Link	Scherenarm	1,80
23	SA0105	2	Snodi	Plaquette	Coupling plate	Zugteilpatte	1,20
24	SA0126	1	Chiusura	Fermeture	Locating	Stecker	3,50
25	SA0109	1	Raccogliatore chiodi	Recuperation clous	Nail collector	Ende Stopsel	1,80
26	SA0106	1	Chiave	Clé	Spanner	Schlüssel	1,50

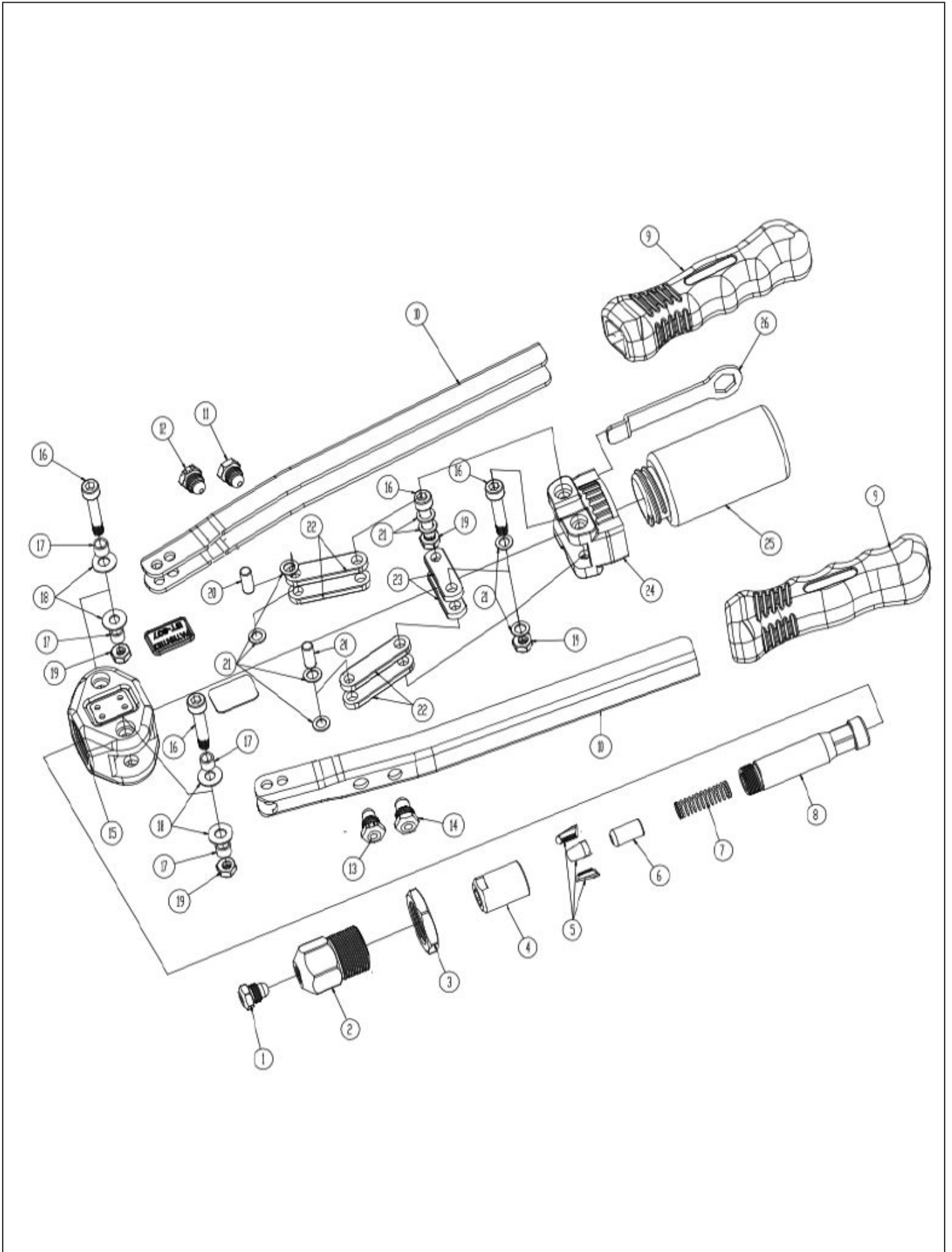



PESO - WEIGHT - GEWICHT	kg 1,900
LUNGHEZZA - LENGHT - GESAMTLANGE	mm 530

RIVETTI BLIND RIVETS BLINDNIETEN	ALLUMINIO ALUMINIUM	ACCIAIO STEEL STAHL	RAME COPPER KUPFER	INOX INOX
3,0 - 3,2	•	•	•	•
4,0	•	•	•	•
4,8	•	•	•	•
6,0	•	•	•	•
6,4	•	•	•	•
7,8	•	•	•	•

POS.	COD.	QT.	DESCRIZIONE	DENOMINATION	PARTS LIST	BEZEICHNUNG	€ cad.
1	10543	1	Raccogliatore chiodi	Recuperation clous	Nail collector	Ende Stopsel	6,20
2	10048	8	Rondella ottone Ø 6	Rondelle	Washer	Scheibe	0,80
3	10080	1	Cono portamorsetti	Tête de tirant	Jaw case	Zugteilkopf	8,00
4	10081	1	Set morsetti (3 pcs)	Mâchoires	Jaws	Klemmbacken	18,60
5	10072	1	Apri morsetti	Poussoir	Jaw pusher	Druckteller	2,60
6	10083	1	Molla premente	Ressort	Spring	Feder	0,60
7	10085	1	Ugello Ø 5	Embout	Nosepiece	Mundstück	2,60
8	10086	1	Ugello Ø 4	Embout	Nosepiece	Mundstück	2,60
9	10088	1	Ugello Ø 6	Embout	Nosepiece	Mundstück	2,60
10	10090	1	Cannotto	Tirant	Inner barrel	Innere Hülse	9,40
11	10093	1	Snodo	Plaquette	Power coupling plate	Zugteilpatte	11,40
12	10094	1	Corpo	Corps	Body	Gehäuse	16,60
13	10111	2	Leve lunghe	Bras	Handle	Hebelarm	12,60
14	10112	2	Impugnatura sogomata	Poignée	Handle grip	Handgriff	4,40
15	10115	4	Leve piccole	Biellette	Link	Scherenarm	5,40
16	10117	6	Rondella UNI 6592 Ø 5 Z.B.	Rondelle	Washer	Scheibe	0,70
17	10118	6	Dado M5 DIN 985	Ecrou	Nut	Mutter	4,00
18	10119	2	Vite TS 2,9x13 Z.B.	Vis	Screw	Schraube	0,30
19	10120	4	Perno Ø 6x30	Axe	Pin	Bolzen	3,30
20	10121	2	Ammortizzatore	Amortisseur	Damper	Stossdämpfer	2,90
21	10122	2	Perno Ø 6x36	Axe	Pin	Bolzen	1,70
22	10087	1	Ugello Ø 3,2	Embout	Nosepiece	Mundstück	2,60
23	10572	1	Tappo racc.chiodi	Bouchon	End plug	Schraub	3,60
24	10571	1	Dado	Ecrou	Nut	Mutter	2,00
25	10888	1	Ugello Ø 6,4	Embout	Nosepiece	Mundstück	2,60
26	10092	1	Asta	Axe	Main shaft	Zug stange	18,00

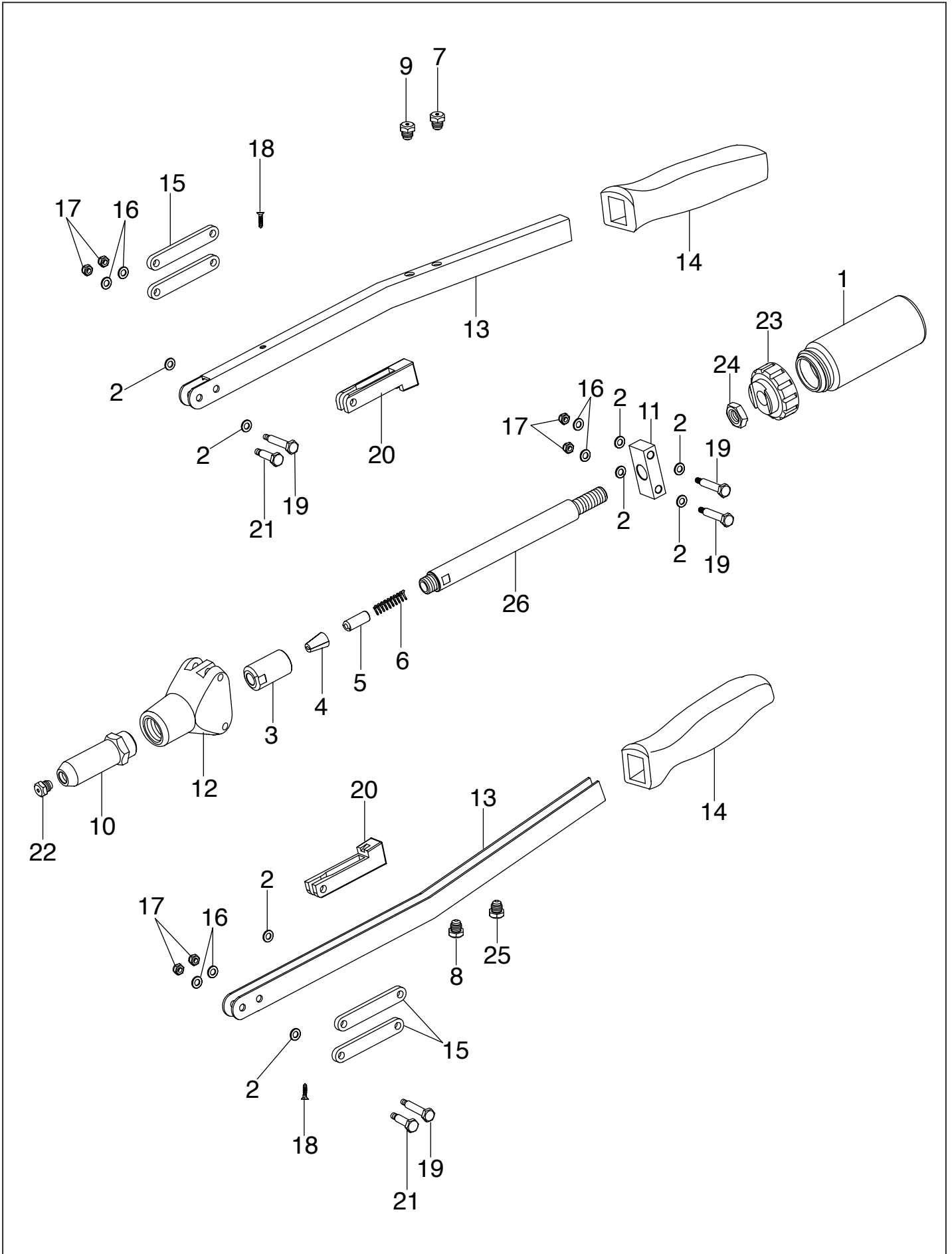

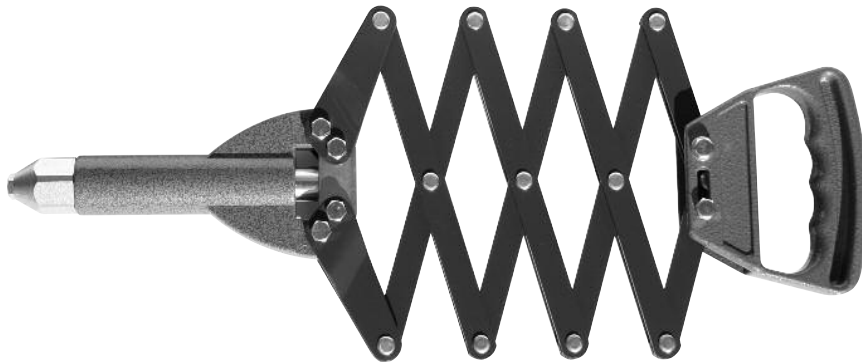

PESO - WEIGHT - GEWICHT	kg 1,900
LUNGHEZZA - LENGHT - GESAMTLANGE	mm 320÷850

RIVETTI BLIND RIVETS BLINDNIETEN	ALLUMINIO ALUMINIUM ALUMINIUM	ACCIAIO STEEL STAHL	RAME COPPER KUPFER	INOX INOX
3,0 - 3,2	•	•	•	•
4,0	•	•	•	•
4,8	•	•	•	•
6,0	•	•	•	•
6,4	•	•	•	•
7,8	•			

POS.	COD.	QT.	DESCRIZIONE	DENOMINATION	DESCRIPTION	BEZEICHNUNG	€ cad.
1	10448	2	Rondella Ø 6,1	Rondelle	Washer	Scheibe	0,70
2	10082	1	Apri morsetti	Ouvre-mâchoires	Jaws opener	Spannbackenöffner	2,60
3	10137	1	Cono porta morsetti	Cone porte mâchoires	Cone holding jaws	Spannbackenhalter	8,00
4	10081	1	Set morsetti (3 pcs)	Mâchoires	Jaws	Spannbacken	18,60
5	10083	1	Molla premente	Ressort	Spring	Feder	0,60
6	10085	1	Ugello Ø 4,8	Embout Ø 4,8	Nosepiece Ø 4,8	Mundstück Ø 4,8	2,60
7	10900	1	Ugello Ø 4	Embout Ø 4	Nosepiece Ø 4	Mundstück Ø 4	2,60
8	10890	1	Ugello Ø 6	Embout Ø 6	Nosepiece Ø 6	Mundstück Ø 6	2,60
9	10098	1	Cannotto	Tête porte mâchoires	Head carrying nosepiece	Düsenträger	9,40
10	10101	1	Corpo	Corps	Body	Gehäuse	22,80
11	10626	2	Inserto corpo	Axe	Pin	Bolzen	2,80
12	10102	1	Asta	Axe	Stem	Zugstange	26,20
13	10103	1	Snodo	Plaquette	Power coupling plate	Zugteilplatte	11,40
14	10110	1	Impugnatura	Poignée	Handle grip	Handgriff	29,20
15	10117	6	Rondella	Rondelle	Washer	Scheibe	0,70
16	10118	6	Dado M5	Ecrou	Nut	Mutter	4,00
17	10120	2	Perno Ø 6 x 30	Tige	Pin 6x30	Bolzen	3,30
18	10125	1	Distanziale Ø 10 x 4	Enretoise	Spacer	Zwischenteil	2,40
19	10126-1	1	Pantografo	Levier	Link	Scherenarm	98,00
20	10131	4	Perno in ferro 6 x 27	Tige	Pin	Bolzen	3,80
21	10132	2	Bussola Ø 8	Enretoise	Spacer	Zwischenteil	1,30
22	10136	2	Distanziale Ø 15 x 5	Enretoise	Spacer	Zwischenteil	2,40
23	10889	1	Ugello Ø 6,4	Embout Ø 6,4	Nosepiece Ø 6,4	Mundstück Ø 6,4	2,60

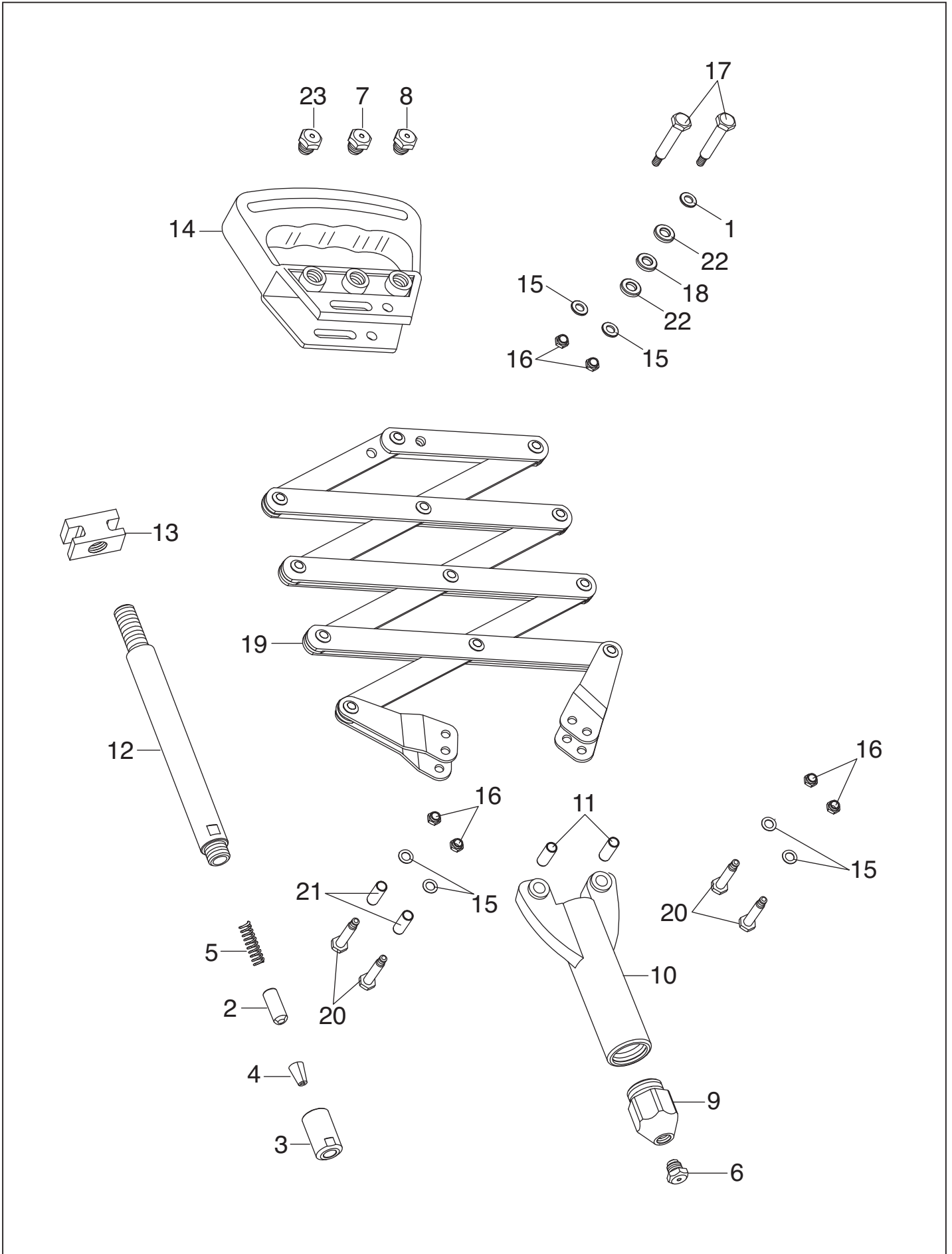



Rivettatrice pneumatica

Pneumatic tool

Pneumatisches Werkzeug

<b>PESO - WEIGHT - GEWICHT</b>	kg 1,30
--------------------------------	---------

Ø	ALLUMINIO ALUMINIUM ALUMINIUM	RAME COPPER KUPFER	ACCIAIO STEEL STAHL	INOX INOX INOX
2,4	•			
3	•	•	•	•
3,2	•	•	•	•
4	•	•	•	•
4,8/5	•			

POS.	COD.	QT.	DESCRIZIONE	DENOMINATION	PARTS LIST	BEZEICHNUNG	€ cad.
1	10416	1	Ugello Ø 4,8	Nosepiece Ø 4,8	Embout Ø 4,8	Mundstück Ø 4,8	4,50
2	10415	1	Cannotto	Head	Tirant	Innere Hülse	24,80
3	104092M	1	Cono porta morsetti	Jaw Housing	Tête di tirant	Spannbackenhalter	20,00
4	107062M	2	Morsetti	Jaws	Etaux	Spannbacken	8,00
5	104072M	1	Apri morsetti	Jaw Pusher	Ouvre-etaux	Druckteller	10,00
6	104052M	1	Molla	Spring	Ressort	Feder	4,00
7	104062M	1	Raccordo cono	Jaw Housing Coupler	Raccord	Zwischenteil	25,50
8	10404	1	Dado	Nut	Ecrou	Mutter	2,00
9	10454	1	O-ring	O-Ring Seal	O-ring	O-ring	4,50
10	10701C	1	Corpo	Housing	Corp	Gehäuse	83,60
11	10913	2	Dado	Nut	Ecrou	Mutter	2,40
12	10912	1	Pistone anteriore	Front Piston	Piston	Kolben	16,80
13	10914	1	Guarnizione	O-Ring Seal	O-Ring	Ring	2,80
14	10706N	1	Asta pistone	Piston Rod	Barre	Kolbenstange	48,60
15	11554	1	Guarnizione	Seal	Garniture	Ring	2,00
16	10719R	1	O-ring	O-Ring	O-Ring	O-Ring	4,80
17	10703C	1	Disco cilindro	Cylinder Cap	Plate	Disc	18,80
18	10704C	3	O-ring	O-Ring Seal	O-Ring	O-Ring	3,20
19	10610C	1	Valvola stelo	Valve Stem	Soupape	Ventiluft	15,40
20	10445	3	O-ring	O-Ring Seal	O-Ring	O-Ring	2,80
21	10607C	1	Bussola valvola	Valve Bushing	Molette	Ventiluft Ring	12,60
22	10720C	1	Vite valvola	Valve Screw	Vis	Schraube	4,70
25	10725C	1	Silenziatore	Silencer	Silencieur	Ventiluft Ring	1,80
26	13514	1	Segeer	Segeer	Segeer	Segeer	3,00
27	13515	1	O-ring	O-Ring	O-Ring	O-Ring	2,00
28	10740C	1	Ammortizzatore	Damping Ring	Ammortisseur	Stossdämpfer	8,00
29	10730C	1	Ammortizzatore	Damping Ring	Ammortisseur	Stossdämpfer	11,00
30	10711C	1	Base	Bush	Cage	Basis	5,60
31	10705C	1	Pistone posteriore	Rear Piston	Piston	Kolben	18,40
32	10720A	1	O-ring	O-Ring Seal	O-Ring	O-Ring	4,20
33	10721C	1	O-ring	O-Ring	O-Ring	O-Ring	3,50
34	10702C	1	Disco di chiusura	Housing Cap	Culot	Stöpsel	46,00
35	10707C	1	O-ring	O-Ring	O-Ring	O-Ring	2,00
36	10937C	1	Grilletto azionamento	Trigger	Bouton	Drucktaster	5,80
37	10927C	1	Perno	Pin	Broche	Stift	2,50
38	10412	1	Ugello Ø 2,4	Nosepiece Ø 2,4	Embout Ø 2,4	Mundstück Ø 2,4	4,50
39	10413	1	Ugello Ø 3,2	Nosepiece Ø 3,2	Embout Ø 3,2	Mundstück Ø 3,2	4,50
40	10414	1	Ugello Ø 4	Nosepiece Ø 4	Embout Ø 4	Mundstück Ø 4	4,50

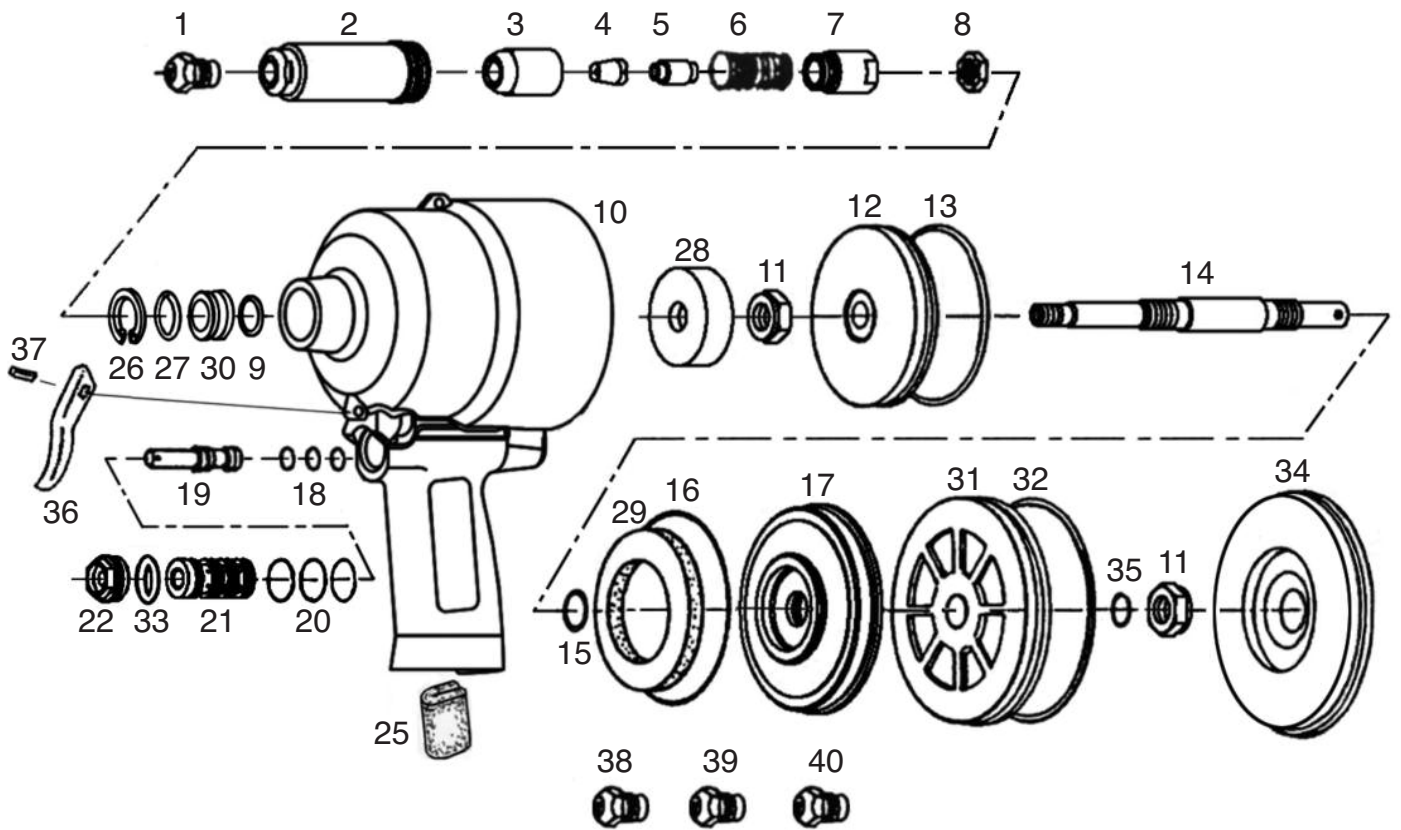



Rivettatrice pneumatica con recupero chiodo

Pneumatic tool with vacuum

Pneumatisches Werkzeug mit Nietdorn

<b>PESO - WEIGHT - GEWICHT</b>	kg 1,50
--------------------------------	---------

Ø	ALLUMINIO ALUMINIUM ALUMINIUM	RAME COPPER KUPFER	ACCIAIO STEEL STAHL	INOX INOX INOX
2,4	•			
3	•	•	•	•
3,2	•	•	•	•
4	•	•	•	•
4,8/5	•			

POS.	COD.	QT.	DESCRIZIONE	DENOMINATION	PARTS LIST	BEZEICHNUNG	€ cad.
1	10416	1	Ugello Ø 4,8	Nosepiece Ø 4,8	Embout Ø 4,8	Mundstück Ø 4,8	4,50
2	10415	1	Cannotto	Head	Tirant	Innere Hülse	24,80
3	104092M	1	Cono porta morsetti	Jaw Housing	Tête di tirant	Spannbackenhalter	20,00
4	107062M	2	Morsetti	Jaws	Etaux	Spannbacken	8,00
5	10407-12M	1	Apri morsetti Ø 3 - 3,4	Jaw Pusher	Ouvre-etaux	Druckteller	10,00
5	10407-22M	1	Apri morsetti Ø 4 - 4,8	Jaw Pusher	Ouvre-etaux	Druckteller	10,00
6	104052M	1	Molla	Spring	Ressort	Feder	4,00
7	104062M	1	Raccordo cono	Jaw Housing Coupler	Raccord	Zwischenteil	25,50
8	10404	1	Dado	Nut	Ecrou	Mutter	2,00
9	10454	1	O-ring	O-Ring Seal	O-ring	O-ring	4,50
10	10701C	1	Corpo	Housing	Corp	Gehäuse	83,60
11	10913	2	Dado	Nut	Ecrou	Mutter	2,40
12	10912	1	Pistone anteriore	Front Piston	Piston	Kolben	16,80
13	10914	1	Guarnizione	O-Ring Seal	O-Ring	Ring	2,80
14	10706NV	1	Asta pistone	Piston Rod	Barre	Kolbenstange	48,60
15	11554	1	Guarnizione	Seal	Garniture	Ring	2,00
16	10719R	1	O-ring	O-Ring	O-Ring	O-Ring	4,80
17	10703C	1	Disco cilindro	Cylinder Cap	Plate	Disc	18,80
18	10704C	3	O-ring	O-Ring Seal	O-Ring	O-Ring	3,20
19	10610C	1	Valvola stelo	Valve Stem	Soupape	Ventiluft	15,40
20	10445	3	O-ring	O-Ring Seal	O-Ring	O-Ring	2,80
21	10607C	1	Bussola valvola	Valve Bushing	Molette	Ventiluft Ring	12,60
22	10720C	1	Vite valvola	Valve Screw	Vis	Schraube	4,70
23	10948C	1	Contenitore chiodi	Bol pour clous	Nail collector	Ende Stopfel	6,90
24	10734D	1	Dado	Nut	Elron	Mutter	3,00
25	10725C	1	Silenziatore	Silencer	Silencieur	Ventiluft Ring	1,80
26	13514	1	Segeer	Segeer	Segeer	Segeer	3,00
27	13515	1	O-ring	O-Ring	O-Ring	O-Ring	2,00
28	10740C	1	Ammortizzatore	Damping Ring	Ammortisseur	Stossdämpfer	8,00
29	10730C	1	Ammortizzatore	Damping Ring	Ammortisseur	Stossdämpfer	11,00
30	10711C	1	Base	Bush	Cage	Basis	5,60
31	10705C	1	Pistone posteriore	Rear Piston	Piston	Kolben	18,40
32	10720A	1	O-ring	O-Ring Seal	O-Ring	O-Ring	4,20
33	10721C	1	O-ring	O-Ring	O-Ring	O-Ring	3,50
34	107020A	1	Disco di chiusura	Housing Cap	Culot	Stöpsel	46,00
35	10707C	1	O-ring	O-Ring	O-Ring	O-Ring	2,00
36	10937C	1	Grilletto azionamento	Trigger	Bouton	Drucktaster	5,80
37	10927C	1	Perno	Pin	Broche	Stift	2,50
38	10412	1	Ugello Ø 2,4	Nosepiece Ø 2,4	Embout Ø 2,4	Mundstück Ø 2,4	4,50
39	10413	1	Ugello Ø 3,2	Nosepiece Ø 3,2	Embout Ø 3,2	Mundstück Ø 3,2	4,50
40	10414	1	Ugello Ø 4	Nosepiece Ø 4	Embout Ø 4	Mundstück Ø 4	4,50

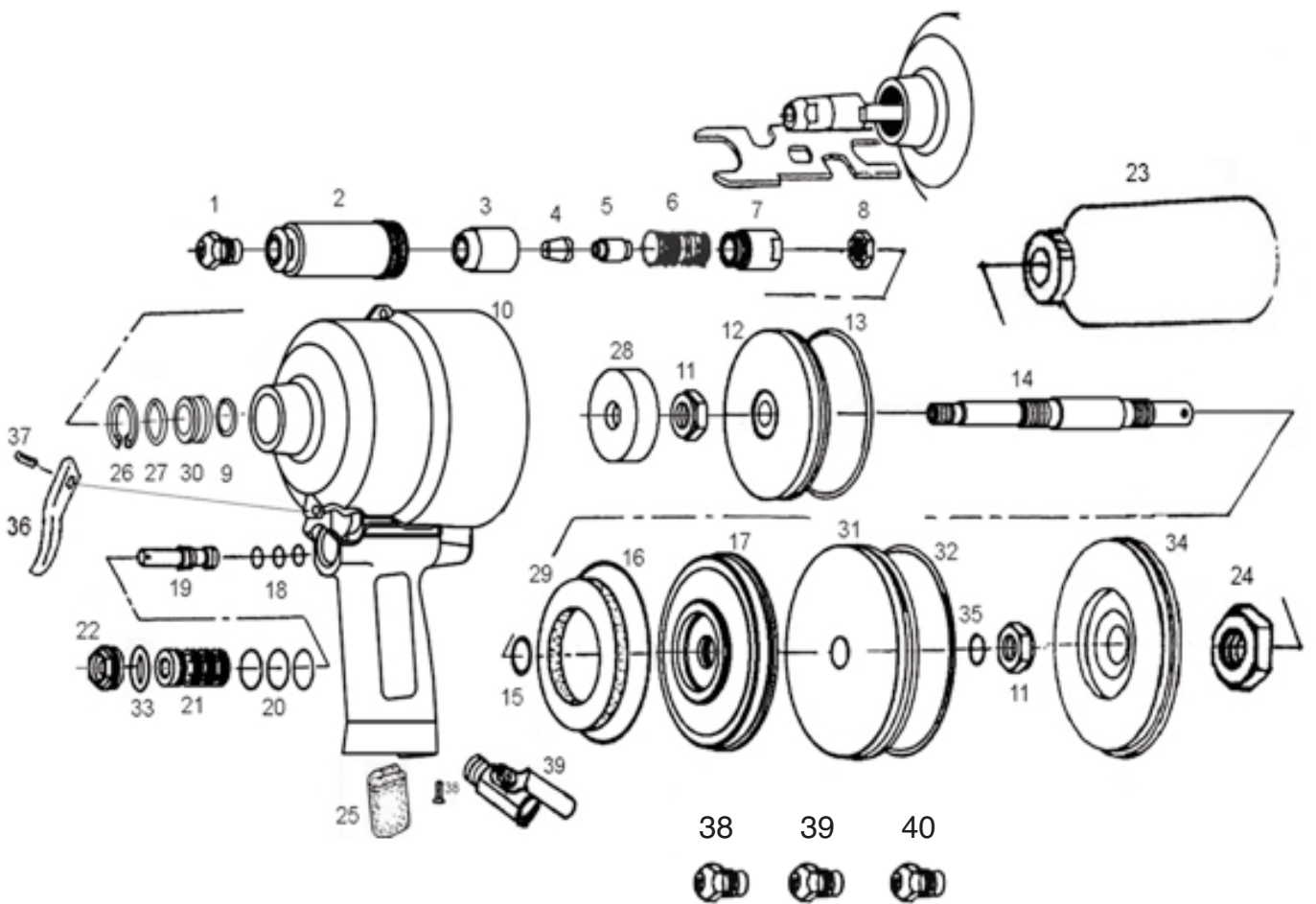

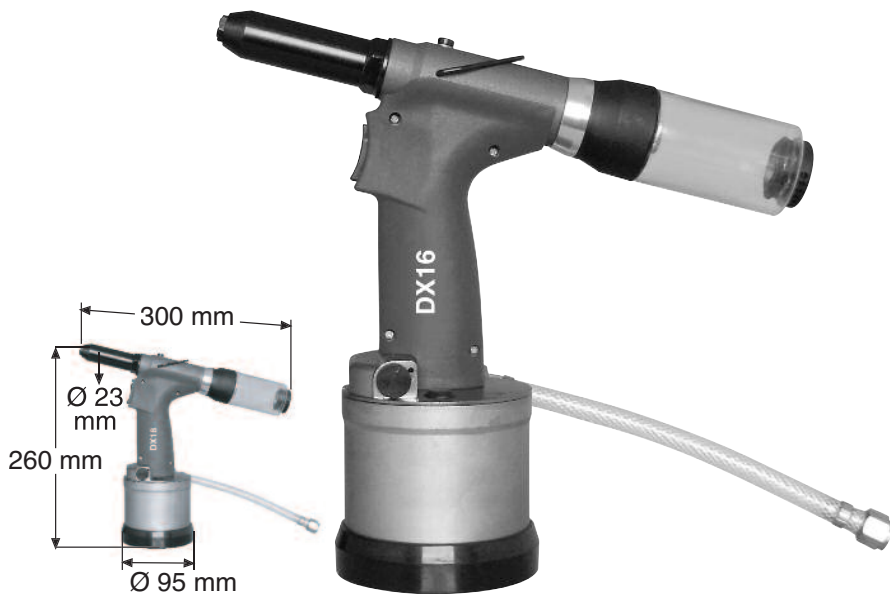

Rivettatrice oleopneumatica con trattenuta del rivetto e recupero del chiodo tranciato

Riveteuse oléopneumatique

Hydropneumatic tool with holding of the rivet and nail recovery

Ölpneumatisches Werkzeug mit Nietdorn-Absaugvorrichtung und Auffangbehälter

<b>PESO - WEIGHT - GEWICHT</b>	kg 1,30
--------------------------------	---------

Ø	ALLUMINIO ALUMINIUM ALUMINIUM	RAME COPPER KUPFER	ACCIAIO STEEL STAHL	INOX INOX INOX
2,4	•			
3	•	•	•	•
3,2	•	•	•	•
4	•	•	•	•
4,8/5	•			

POS.	COD.	QT.	DESCRIZIONE	DENOMINATION	PARTS LIST	BEZEICHNUNG	€ cad.
1	10701	1	Ugello Ø 5	Embout Ø 5	Nosepiece Ø 5	Mundstück Ø 5	7,00
2	11702	1	OR	O-ring	O-ring	O-Ring	4,00
3	11703	1	Cannotto	Tête porte embout	Head carrying nosepiece	Düsenträger	21,00
4	11704	1	Cono morsetti	Cone porte étaux	Cone holding jaws	Spannbackenhalter	18,00
5	11705	3	Morsetti	Etaux	Jaws	Spannbacken	8,00
6	11706-1	1	Apri morsetti piccolo Ø 3,4	Ouvre-étaux Ø 3,4	Jaws opener Ø 3,4	Spannbackenöffner Ø 3,4	18,00
6	11706-2	1	Apri morsetti grande Ø 4	Ouvre-étaux Ø 4	Jaws opener Ø 4	Spannbackenöffner Ø 4	18,00
7	11707	1	Molla	Ressort retour	Jaws return spring	Feder z. Spannbackenrücklauf	3,00
8	-	-	-	-	-	-	-
9	11708	1	Porta cono	Porte cone	Cone holder	Kopfhäler	8,40
10	11709	1	Dado	Ecrou	Nut	Mutter	2,00
11	11710	2	OR	O-ring	O-ring	O-Ring	2,40
12	11711	1	Guarnizione	Balsele	Balsele	Balsele	12,00
13	11712B	1	Cilindro testa	Cylindre tete	Head cylinder	Kopfzylinder	176,00
14	10783	1	OR	OR	OR	OR	8,00
15	10784	1	Tappo olio	Bouchon oil	Screw	Schraub	4,80
16	10785	1	Gancio	Crochet	Hook	Haken	3,00
17	11713	2	Balsele	Balsele	Balsele	Balsele	12,00
18	11714	1	Anello teflon	Balsele	Balsele	Balsele	12,00
19	11715	1	Pistone	Piston	Piston	Kolben	69,60
20	11716	1	Molla	Ressort	Spring	Feder	11,20
21	11717	1	OR	O-ring	O-ring	O-Ring	2,00
22	11772	1	OR	O-ring	O-ring	O-Ring	4,00
23	11773	1	supporto	support	Support	lager	25,00
24	11774	1	Attacco contenitore	Attache	Connection	Schaftanschlussstück	6,70
25	11775	1	OR	O-ring	O-ring	O-Ring	0,80
26	11776	1	Dado	Ecrou	Nut	Mutter	2,50
27	11777	1	OR	O-ring	O-ring	O-Ring	1,00
28	11778	1	Regolatore aspirazione	Regulateur aspiration	Vacuum switch	Nut muttern	14,00
29	11779	1	Contenitore chiodi	Bol pour clous	Nail collector	Ende Stopfel	7,00
30	11730	2	Impugnatura coppia	Poignée	Handle	Nägel Behälter	12,00
31	11739	6	Vite	Vis	Screw	Ventilluft Korp	0,60
32	10742	1	Grilletto	Levier	Trigger	Anschlussstück	8,40
33	11733	1	Pulsante grilletto	Bouton levier	Trigger leve	Drehbares	2,40
34	11734	1	Valvola	Soupape	Valve	O-Ring	12,00
35	10745	4	OR	O-ring	O-ring	Schalldämpfer	2,40
36	11736	4	Raccordo	Raccord	Connector	Zwischenteil	2,40
37	11737	4	Distanziale plastica	Entretoise	Spacer	Luftrohr	2,00
38	11738	2	Tube aria	Tuyau air	Air tube	Schraub	2,80
39	11740	1	Corpo valvola aria	Corp soupape	Air valve body	Ventilluft Ring	42,00
40	11741	1	Anello valvola aria	Bauge soupape	Air valve ring	O-Ring	6,00
41	10756	2	OR	O-ring	O-ring	Mundstück	4,00
42	11743	1	Guarnizione	OR	OR	OR	2,80
43	11744	1	Pistone	Piston	Piston	Piston	8,80
44	11745	2	OR	O-ring	O-ring	O-Ring	4,00

POS.	COD.	QT.	DESCRIZIONE	DENOMINATION	PARTS LIST	BEZEICHNUNG	€ cad.
45	11746	1	Raccordo	Raccord	Connector	Schraub	6,00
46	11747	1	OR	O-ring	O-ring	O-Ring	2,50
47	10762	1	Raccordo girevole	Raccord evoluable	Rotating valve	Drehbares Anschlussstück	48,00
48	11749	1	Tirante valvola	Tige soupape	Valve rod	Drehbaresbolzen	12,00
49	11750	1	Tappo	Bouchon	Stopper	Stop	3,00
50	11751	1	Silenziatore	Silencieur	Silencer	Ventilluft Ring	1,30
51	11752B	1	Fondello cilindro	Culot de protection	Cylinder bottom	Bondemscheibe	24,00
52	11753	1	OR	O-ring	O-ring	O-Ring	5,80
53	11754	2	Vite	Vis	Screw	Schraub	2,00
54	11755B	1	Ghiera	Embout	Pin	O-Ring	4,00
55	11756	2	Ammortizzatore	Ammortisseur	Buffer	Stossdämpfer	2,40
56	10772	2	Rondella teflon	Rondelle teflon	Teflon ring	Teflon Ring	8,40
57	10773	1	Pistone	Piston pneumatique	Air tube piston	Drehbares Anschlussstück	24,00
58	10771	1	OR	O-ring	O-ring	O-Ring	8,00
59	11760	1	Rondella pistone	Rondelle	Piston ring	Kolbenring	4,00
60	11761	1	Tube	Tuyau	Tube	Rohr	9,80
61	11762	1	Stelo	Tige	Stem	Schaft	32,80
62	11763	1	Pistone pneumatico	Piston pneumatique	Pneumatic piston	Pneumatischer Kolben	35,60
63	11764	1	OR	O-ring	O-ring	O-Ring	11,50
64	11765	1	OR	O-ring	O-ring	O-Ring	3,00
65	11766	1	Vite	Vis	Screw	Schraub	1,60
66	11767	1	Cilindro	Cylindre	Cylinder	Zylinder	51,00
67	11768	1	Fondello di protezione	Culot de protection	Protection bottom	Schutzscheibe	6,00
68	10786	1	Ugello Ø 2,4	Embout Ø 2,4	Nosepiece Ø 2,4	Mundstück Ø 2,4	7,00
69	10787	1	Ugello Ø 3-3,2-3,4	Embout Ø 3-3,2-3,4	Nosepiece Ø 3-3,2-3,4	Mundstück Ø 3-3,2-3,4	7,00
70	10788	1	Ugello Ø 4	Embout Ø 4	Nosepiece Ø 4	Mundstück Ø 4	7,00
	10819	1	Siringa	Seringue	Syringe	Spritze	9,00
	10820	1	Bottiglia olio	Bouteille huile	Oil bottle	Öl Flasche	3,00
	10821	1	Chiave brugola	Vis Allen	Allen screw	Innensechskantschlüssel	4,00

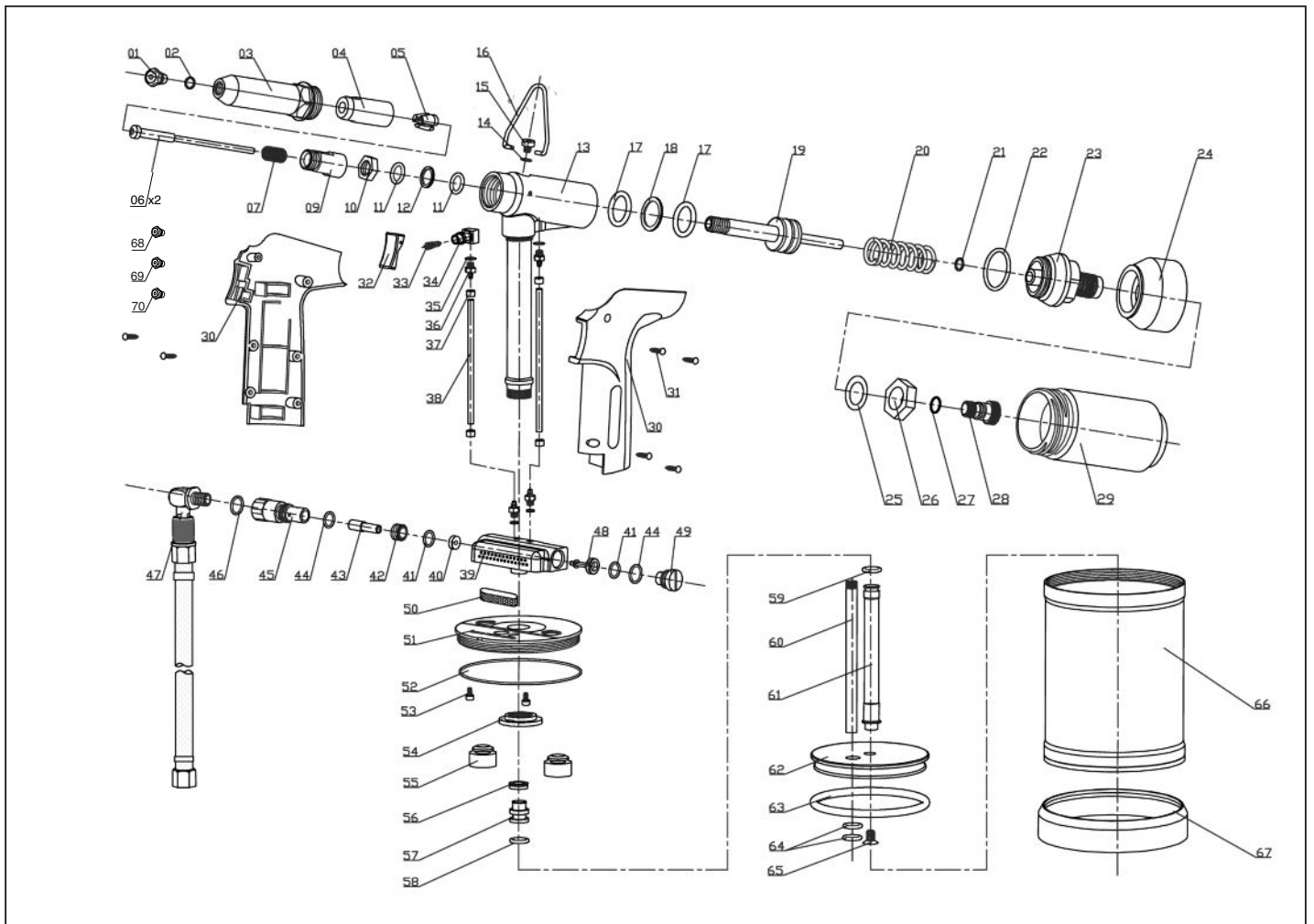



Rivettatrice oleopneumatica con trattenuta del rivetto e recupero del chiodo tranciato

Riveteuse oléopneumatique

Hydropneumatic tool with holding of the rivet and nail recovery

Ölpneumatisches Werkzeug mit Nietdorn-Absaugvorrichtung und Auffangbehälter

<b>PESO - WEIGHT - GEWICHT</b>	kg 1,50
--------------------------------	---------

Ø	ALLUMINIO ALUMINIUM ALUMINIUM	RAME COPPER KUPFER	ACCIAIO STEEL STAHL	INOX INOX INOX
2,4	•			
3	•	•	•	•
3,2	•	•	•	•
4	•	•	•	•
4,8/5	•	•	•	•

POS.	COD.	QT.	DESCRIZIONE	DENOMINATION	PARTS LIST	BEZEICHNUNG	€ cad.
1	10701	1	Ugello Ø5	Embout Ø 5	Nosepiece Ø5	Mundstück Ø 4,8	7,00
2	10702	1	OR	O-ring	O-ring	O-Ring	4,00
3	10703	1	Cannotto	Tête porte embout	Head carrying nosepiece	Düsenträger	21,00
4	10704	1	OR	O-ring	O-ring	O-Ring	4,00
5	10705	1	Cono morsetti	Cone porte étaux	Cone holding jaws	Spannbackenhalter	18,00
6	10706	3	Morsetti	Mâchoires	Jaws	Spannbacken	8,00
7	10707	1	Apri morsetti	Ouvre-étaux	Jaws opener	Spannbackenöffner	6,00
8							
9	10709	1	Molla	Ressort retour	Jaws return spring	Feder z. Spannbackenrücklauf	3,00
10	10710	1	OR	O-ring	O-ring	O-Ring	4,00
11	10711	1	Porta cono	Porte-cone	Cone holder	Kopfhalter	11,00
12	10712	1	OR	O-ring	O-ring	O-Ring	6,60
13	10713	1	Raccordo	Raccord	Connector	Anschlussstück	11,10
14	10714	1	OR	O-ring	O-ring	O-Ring	6,60
15	10715	1	OR	O-ring	O-ring	O-Ring	2,40
16	10716	1	Tubo aspirazione	Tuyan	Tube	Luftrohr	5,00
17	10717	1	Distanziale	Entretoise	Plastic seal	Plastic Ring	10,80
18	10718	1	Guarnizione	O-ring	Seal	Ring	12,40
19	10719 B	1	Cilindro testa	Cylindre tete	Head cylinder	Kopfzylinder	192,00
20	10720	1	OR	O-ring	O-ring	O-Ring	12,40
21	10721	1	Anello anti estrusione	Bauge anti-extrusion	Anti-extrusion ring	Ring Antiextrusion	2,00
22	10722	2	OR	O-ring	O-ring	O-Ring	3,00
23	10723	1	Anello teflon	Bauge teflon	Teflon ring	Teflon Ring	12,50
24	10724	1	Pistone	Piston	Piston	Kolben	69,00
25	10791	1	Molla	Ressort	Sring	Feder	8,10
26	10792	1	OR	O-ring	O-ring	O-Ring	9,00
27	10793	1	Guarnizione	O-ring	Seal	Ring	5,00
28	10794	1	Adattatore	Raccord	Fitting	Anschlusstück	28,00
29	10795	1	Attacco contenitore	Attache	Connection	Schaftanschlussstück	6,50
30	10796	1	OR	O-ring	O-ring	O-Ring	3,00
31	10797	1	Dado	Ecrou	Nut	Mutter	8,00
32	10790	1	Contenitore chiodi	Bol pour clous	Nail collector	Ende Stopfel	10,00
33	10740	2	Coppia impugnatura	Poignée	Handle	Hebelarm	18,00
34	10742	1	Grilletto	Levier	Trigger	Drucktaste	8,40
35	10743	1	Pulsante grilletto	Bouton levier	Trigger leve	Drucktaste Hebel	2,40
36	10744	1	Valvola	Soupape	Valve	Drehbar	12,00
37	10745	6	OR	O-ring	O-ring	O-Ring	2,40
38	10746	6	Raccordo	Raccord	Air valve	Ventilluft	2,40
39	10747	6	Distanziale	Entretoise	Spacer	Zwischenteil	2,00
40	10748	3	Tubo aria	Tuyau air	Air tube	Luftrohr	2,80
41	10749	1	regolazione	Embout	Ring nut	Nut Muttern	5,00
42	10750	1	Vite	Vis	Screw	Schraub	1,00
43	10751	1	Valvola	Soupape	Valve	Ventil	11,00
44	10752	2	OR	O-ring	O-ring	O-Ring	2,40
45	10753	4	Vite	Vis	Screw	Schraub	2,00
46	10754	1	Corpo valvola aria	Corp soupape	Air valve body	Ventilluft Korp	66,00
47	10755	1	Anello valvola aria	Bauge soupape	Air valve ring	Ventilluft Ring	6,40

POS.	COD.	QT.	DESCRIZIONE	DENOMINATION	PARTS LIST	BEZEICHNUNG	€ cad.
48	10756	2	OR	O-ring	O-ring	O-Ring	4,00
49	10757	1	Base valvola aria	Base soupape	Air valve base	Ventilluft	4,20
50	10758	1	Pistone valvola	Piston	Piston	Kolben	8,80
51	10759	2	OR	O-ring	O-ring	O-Ring	4,00
52	10760	1	Raccordo	Raccord	Connector	Anschlussstück	12,00
53	10761	1	OR	O-ring	O-ring	O-Ring	2,50
54	10762	1	Raccordo girevole	Raccord evolvable	Rotating valve	Drehbares Anschlussstück	48,00
55	10763	1	Tirante valvola	Tige soupape	Valve rod	Drehbaresbolzen	12,00
56	10764	1	Tappo	Bouchon	Stopper	Stop	3,00
57	10765	1	Silenziatore	Silencieur	Silencer	Schalldämpfer	1,30
58	10766 B	1	Fondello cilindro	Culot de protection	Cylinder bottom	Bondemscheibe	42,00
59	10767	1	OR	O-ring	O-ring	O-Ring	6,70
60	10768	2	Vite	Vis	Screw	Schraub	2,00
61	10769 B	1	Ghiera	Embout	Pin	Stift	4,00
62	10770	2	Ammortizzatore	Ammortisseur	Buffer	Stossdämpfer	6,00
63	10771	1	OR	O-ring	O-ring	O-Ring	8,00
64	10772	1	Rondella teflon	Rondelle teflon	Teflon ring	Teflon Ring	8,40
65	10773	1	Pistone	Piston pneumatique	Air tube piston	Kolben	24,00
66	10774	1	Rondella pistone	Rondelle	Piston ring	Kolbenring	4,00
67	10775	1	Tube	Tuyau	Tube	Rohr	12,00
68	10776	1	Stelo	Tige	Stem	Schaft	33,00
69	10777	1	Pistone pneumatico	Piston pneumatique	Pneumatic piston	Pneumatischer Kolben	35,60
70	10778	1	OR	O-ring	O-ring	O-Ring	12,60
71	10779	1	Vite	Vis	Screw	Schraub	2,50
72	10780	2	OR	O-ring	O-ring	O-Ring	5,00
73	10781	1	Cilindro	Cylindre	Cylinder	Zylinder	84,00
74	10782	1	Fondello di protezione	Culot de protection	Protection bottom	Schutzscheibe	7,00
75	10783	1	Guarnizione	Garniture	Gasket	Ring	6,60
76	10784	1	Tappo olio	Bouchon oil	Screw	Schraub	4,80
77	10785	1	Gancio	Crochet	Hook	Haken	3,00
78	10786	1	Ugello Ø 2,4	Embout Ø 2,4	Nosepiece Ø 2,4	Mundstück Ø 2,4	7,00
79	10787	1	Ugello Ø 3-3,2-3,4	Embout Ø 3-3,2-3,4	Nosepiece Ø 3-3,2-3,4	Mundstück Ø 3-3,2-3,4	7,00
80	10788	1	Ugello Ø 4	Embout Ø 4	Nosepiece Ø 4	Mundstück Ø 4	7,00
10819		1	Siringa	Seringue	Syringe	Spritze	9,00
10820		1	Bottiglia olio	Bouteille huile	Oil bottle	Öl Flasche	3,00
10821		1	Chiave brugola	Vis Allen	Allen screw	Innensechskantschlüssel	4,00

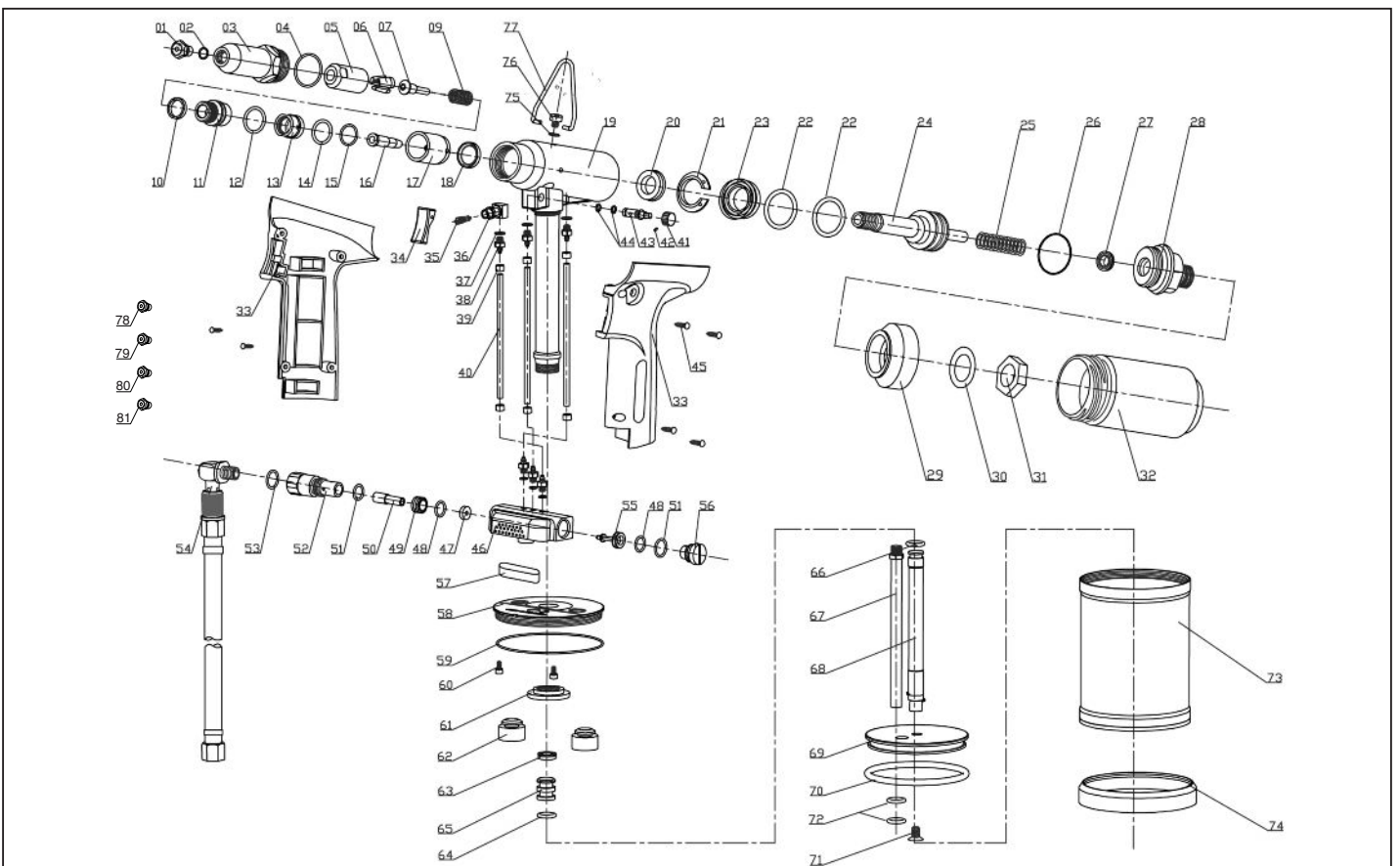

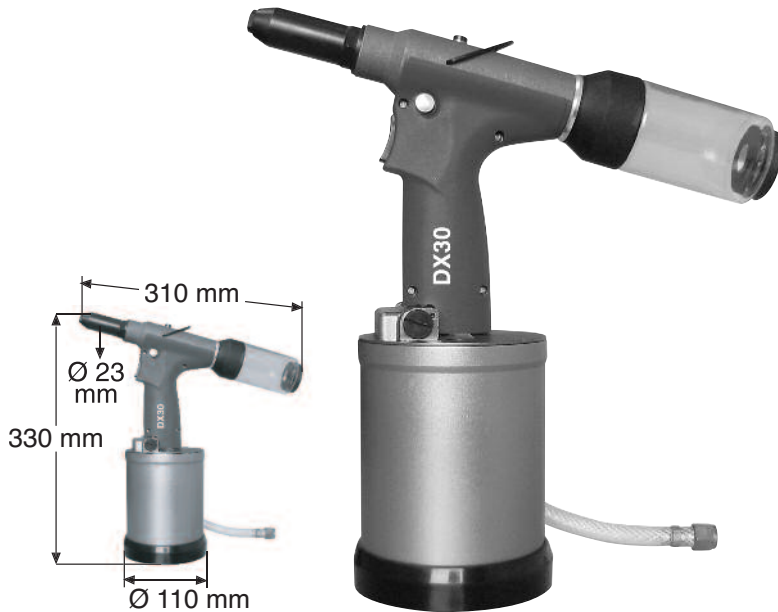

Rivettatrice oleopneumatica con trattenuta del rivetto e recupero del chiodo tranciato per rivetti a strappo e rivetti **strutturali unibolt**

Hydropneumatic tool with holding of the rivet and nail recovery for blind rivets and structural **rivets unibolt**

Ölpneumatisches Werkzeug mit Nietdorn-Absaugvorrichtung und Auffangbehälter für Blindniete und structurelle **Blindniete unibolt**

<b>PESO - WEIGHT - GEWICHT</b>	kg 1,70
--------------------------------	---------

Ø	ALLUMINIO ALUMINIUM ALUMINIUM	UNIBOLT MAGNA- LOCK	ACCIAIO STEEL STAHL	INOX INOX INOX
4	•		•	•
4,8/5	•	•	•	•
6	•		•	•
6,4	•	•	•	•
7,8	•			

POS.	COD.	QT.	DESCRIZIONE	DENOMINATION	PARTS LIST	BEZEICHNUNG	€ cad.
1	10701	1	Ugello Ø 4,8	Embout Ø 4,8	Nosepiece Ø 4,8	Mundstück Ø 4,8	7,00
2	10902	1	OR	O-Ring	O-ring	O-Ring	4,00
3	10703	1	Cannotto	Tête porte embout	Head carrying nosepiece	Düsenträger	21,00
4	10704	1	OR	O-Ring	O-ring	O-Ring	4,00
5	10905	1	Cono morsetti	Cone porte mâchoires	Cone holding jaws	Spannbackenhalter	18,00
6	10906	3	Morsetti	Mâchoires	Jaws	Spannbacken	9,00
7	10907*	1	Apri morsetti	Ouvre-mâchoires	Jaws opener	Spannbackenöffner	6,20
8	10908	1	Rondella	Rondelle	Washer	Federring	6,00
9	10909*	1	Molla	Ressort retour	Jaws return spring	Feder z. Spannbackenrücklauf	3,00
10	10710	1	OR	O-Ring	O-ring	O-Ring	4,00
11	10711	1	Porta cono	Porte-cone	Cone holder	Kopfhalter	11,00
12	10712	1	OR	O-Ring	O-ring	O-Ring	6,60
13	10713	1	Raccordo	Raccord	Connector	Anschlussstück	11,10
14	10714	1	OR	O-Ring	O-ring	O-Ring	6,60
15	10715	1	OR	O-Ring	O-ring	O-Ring	2,40
16	10916	1	Tube aspirazione	Tuyan	Tube	Luftrohr	6,60
17	10717	1	Distanziale	Entretoise	Plastic seal	Plastic Ring	10,80
18	10718	1	Guarnizione	Balsele	Seal	Ring	12,40
19	10919B	1	Cilindro testa	Cylindre tete	Head cylinder	Kopfzylinder	212,00
20	10720	1	OR	O-Ring	O-ring	O-Ring	7,20
21	10721	1	Anello anti estrusione	Bauge anti-extrusion	Anti-extrusion ring	Ring Antiextrusion	2,00
22	10722	2	OR	O-Ring	O-ring	O-Ring	3,00
23	10723	1	Anello teflon	Bauge teflon	Teflon ring	Teflon Ring	6,40
24	10924	1	Pistone	Piston	Piston	Kolben	76,80
25	10791	1	Molla	Ressort	Sring	Feder	4,00
26	10792	1	OR	O-ring	O-ring	O-Ring	9,00
27	10793	1	Guarnizione	O-ring	Seal	Ring	5,00
28	10794	1	Adattatore	Raccord	Fitting	Anschlusstück	28,00
29	10795	1	Attacco contenitore	Attache	Connection	Schaftanschlussstück	6,50
30	10796	1	OR	O-ring	O-ring	O-Ring	3,00
31	10797	1	Dado	Ecrou	Nut	Mutter	8,00
32	10790	1	Contenitore chiodi	Bol pour clous	Nail collector	Ende Stoppel	10,00
33	10940	1	Coppia impugnatura	Poignée	Handle	Hebelarm	18,00
34	10742	1	Grilletto	Levier	Trigger	Drucktaste	8,40
35	10943	1	Pulsante grilletto	Bouton levier	Trigger leve	Drucktaste Hebel	2,40
36	10944	1	Valvola	Soupape	Valve	Drehbar	12,00
37	10745	6	OR	O-Ring	O-ring	O-Ring	2,40
38	10946	6	Raccordo	Raccord	Air valve	Ventilluft	3,00
39	10947	6	Distanziale	Entretoise	Spacer	Zwischenteil	4,00
40	10948	3	Tube aria	Tuyau air	Air tube	Luftrohr	3,00
41	10749	1	Ghiera regolazione	Embout	Ring nut	Nut Muttern	5,00
42	10750	1	Vite	Vis	Screw	Schraub	1,00
43	10751	1	Valvola	Soupape	Valve	Ventil	11,00
44	10752	2	OR	O-Ring	O-ring	O-Ring	2,40
45	10753	4	Vite	Vis	Screw	Schraub	2,00
46	10954	1	Corpo valvola aria	Corp soupape	Air valve body	Ventilluft Korp	84,00
47	10755	1	Anello valvola aria	Bauge soupape	Air valve ring	Ventilluft Ring	6,40
48	10756	2	OR	O-Ring	O-ring	O-Ring	4,00
49	10957	1	Base valvola aria	Base soupape	Air valve base	Ventilluft	4,20
50	10958	1	Raccordo	Raccord	Connector	Anschlussstück	10,00
51	10759	2	OR	O-Ring	O-ring	O-Ring	4,00

POS.	COD.	QT.	DESCRIZIONE	DENOMINATION	PARTS LIST	BEZEICHNUNG	€ cad.
52	10960	1	Raccordo	Raccord	Connector	Anschlussstück	12,00
53	10761	1	OR	O-Ring	O-ring	O-Ring	2,50
54	10762	1	Raccordo girevole	Raccord evoluable	Rotating valve	Drehbares Anschlussstück	48,00
55	10963	1	Tirante valvola	Tige soupape	Valve rod	Drehbaresbolzen	12,00
56	10764	1	Vite	Vis	Screw	Schraub	3,00
57	10965	1	Silenziatore	Silencieur	Silencer	Schalldämpfer	1,30
58	10966B	1	Fondello cilindro	Culot de protection	Cylinder bottom	Bondemscheibe	50,00
59	10967	1	OR	O-Ring	O-ring	O-Ring	6,70
60	10968	2	Vite	Vis	Screw	Schraub	2,00
61	10969B	1	Ghiera	Embout	Pin	Stift	4,00
62	10970	2	Ammortizzatore	Ammortisseur	Buffer	Stossdämpfer	6,00
63	10771	1	OR	O-Ring	O-ring	O-Ring	8,00
64	10772	1	Rondella teflon	Rondelle teflon	Teflon ring	Teflon Ring	8,40
65	10973	1	Pistone	Piston	Air tube piston	Kolben	24,00
66	10974	1	Rondella pistone	Rondelle	Piston ring	Kolbenring	4,40
67	10975	1	Tube	Tuyau	Tube	Rohr	6,00
68	10976	1	Stelo	Tige	Stem	Schaft	33,00
69	10977	1	Pistone pneumatico	Piston pneumatique	Pneumatic piston	Pneumatischer Kolben	40,00
70	10978	1	OR	O-Ring	O-ring	O-Ring	12,60
71	10979	1	Vite	Vis	Screw	Schraub	2,50
72	10980	2	OR	O-ring	O-ring	O-ring	5,00
73	10981	1	Cilindro	Cylindre	Cylinder	Zylinder	110,60
74	10982	1	Fondello di protezione	Culot de protection	Protection bottom	Schutzscheibe	7,00
75	10783	1	Guarnizione	Garniture	Gasket	Ring	6,60
76	10784	1	Tappo olio	Bouchon oil	Screw	Schraub	4,80
77	10785	1	Gancio	Crochet	Hook	Haken	3,00
78	10788	1	Ugello Ø 4	Embout Ø 4	Nosepiece Ø 4	Mundstück Ø 4	7,00
79	10987	1	Ugello Ø 6 - 6,4 - 7,8	Embout Ø 6 - 6,4 - 7,8	Nosepiece Ø 6 - 6,4 - 7,8	Mundstück Ø 6 - 6,4 - 7,8	7,00
80	10988*	1	Ugello per unibolt Ø 5	Embout unibolt Ø 4,8	Nosepiece unibolt Ø 5	Mundstück unibolt Ø 5	19,20
81	10989*	1	Ugello per unibolt Ø 6,4	Embout unibolt Ø 6,4	Nosepiece unibolt Ø 6,4	Mundstück unibolt Ø 6,4	19,20
82	10990*	3	Morsetti per unibolt	Mâchoires pour unibolt	Jaws for unibolt	Spannbacken für unibolt	11,60
83	10991*	1	Cono morsetti per unibolt	Cone mâchoires pour unibolt	Cone holding for unibolt	Spannbackenhalter für unibolt	25,00
84	10992	1	Ugello magnalock Ø 4,8	Embout	Nosepiece	Mundstück	18,00
85	10993	1	Ugello magnalock Ø 6,4	Embout	Nosepiece	Mundstück	18,00
	10819	1	Siringa	Seringue	Syringe	Spritze	9,00
	10820	1	Bottiglia olio	Bouteille huile	Oil bottle	Öl Flasche	3,00
	10821	1	Chiave brugola	Vis Allen	Allen screw	Innensechskantschlüssel	4,00
A	KIT10988	1	Kit per unibolt ø 5,0	composto da 10988+10990+10991+10907+10909			80,00
RICHIESTA	KIT10989	1	Kit per unibolt ø 6,4	composto da 10989+10990+10991+10907+10909			80,00

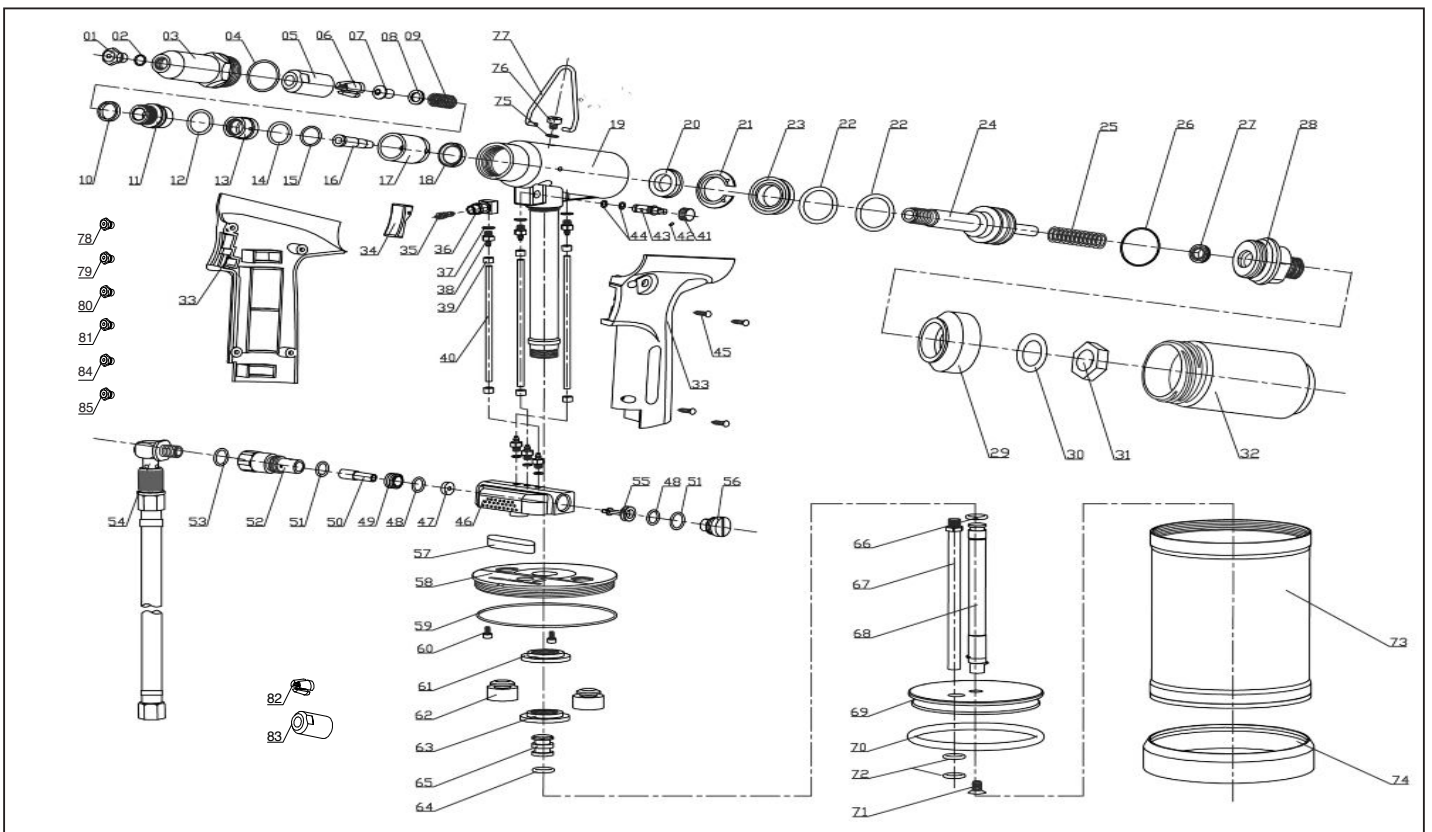

Rivettatrice per inserti filettati con tiranti da M3-M4-M5

Tool for threaded inserts M3-M4-M5

Handwerkzeug für Blindnietmuttern M3-M4-M5



PESO - WEIGHT - GEWICHT	kg 0,500
LUNGHEZZA - LENGHT - GESAMTLANGE	mm 200

RIVETTI BLIND RIVETS BLINDNIETEN	ALLUMINIO ALUMINIUM ALUMINIUM	ACCIAIO STEEL STAHL	INOX INOX INOX
M3	•	•	•
M4	•	•	•
M5	•	•	•

POS.	COD.	QT.	DESCRIZIONE	DENOMINATION	PARTS LIST	BEZEICHNUNG	€ cad.
1	X4401	1	Vite	Vis	Screw	Schraub	1,00
2	X4402	1	Dado	Ecrou	Nut	Muttern	1,20
3	X4403	2	Rondella inox	Rondelle	Washer	Schelbe	0,60
4	X4404	1	Chiusura	Fermeture	Locating ring	Stecker	1,20
5	X4405	1	Pistone	Piston	Piston	Kolben	5,60
6	X4406	1	Cannotto	Cone	Barrel	Hülse	7,40
7	X4407	2	Rondella inox	Rondelle	Washer	Schelbe	0,60
8	X4408	1	Molla	Ressort	Spring	Feder	0,80
9	X4409	1	Cilindro scorrevole	Cylindre	Roller	Zylinder	3,20
10	X4410	1	Rondella inox	Rondelle	Washer	Schelbe	0,50
11	X4411	1	Ghiera di regolazione	Embout	Ring nut	Nut Mutter	2,00
12	X4412	1	Cilindro esterno	Cylindre externe	Cylinder	Zylinder	8,60
13	X4413	2	Perno	Axe	Pin rod	Bolzen	0,60
14	X4414	1	Perno	Axe	Pin rod	Bolzen	0,60
15	X4415	1	Leva	Bras	Link	Link	1,00
16	X4416	1	Leva superiore	Bras sup.	Pliers lever	Hebelgriff	8,40
17	X4417	1	Impugnatura superiore	Poignée sup.	Handle grip	Griff	1,60
18	X4418	1	Molla torsione	Ressort	Spring	Feder	1,00
19	X4419	1	Gancio	Croceht	Hook	Haken	1,20
20	X4420	1	Impugnatura inf.	Poignée inf.	Handle grip	Griff	1,60
21	X4421	1	Corpo in alluminio	Corps alu	Pliers body	Zangenschaft	9,80
22	X4422	1	Dado M6	Ecru M6	Nut M6	Mutter M6	0,70
23	X4423	1	Vite M6	Vis M6	Screw M6	Schraub M6	0,80
24	X4424	4	Vite	Vis	Screw	Scharaub	0,80
25	X4425	1	Testa M3	Tête M3	Head	Kopfteil	4,80
26	X4426	1	Tirante M3	Tirant M3	Tie rod	Zugbolzen	4,20
27	X4427	1	Testa M4	Tête M4	Head	Kopfteil	4,80
28	X4428	1	Tirante M4	Tirant M4	Tie rod	Zugbolzen	4,20
29	X4429	1	Testa M5	Tête M5	Head	Kopfteil	4,80
30	X4430	1	Tirante M5	Tirant M5	Tie rod	Zugbolzen	4,20

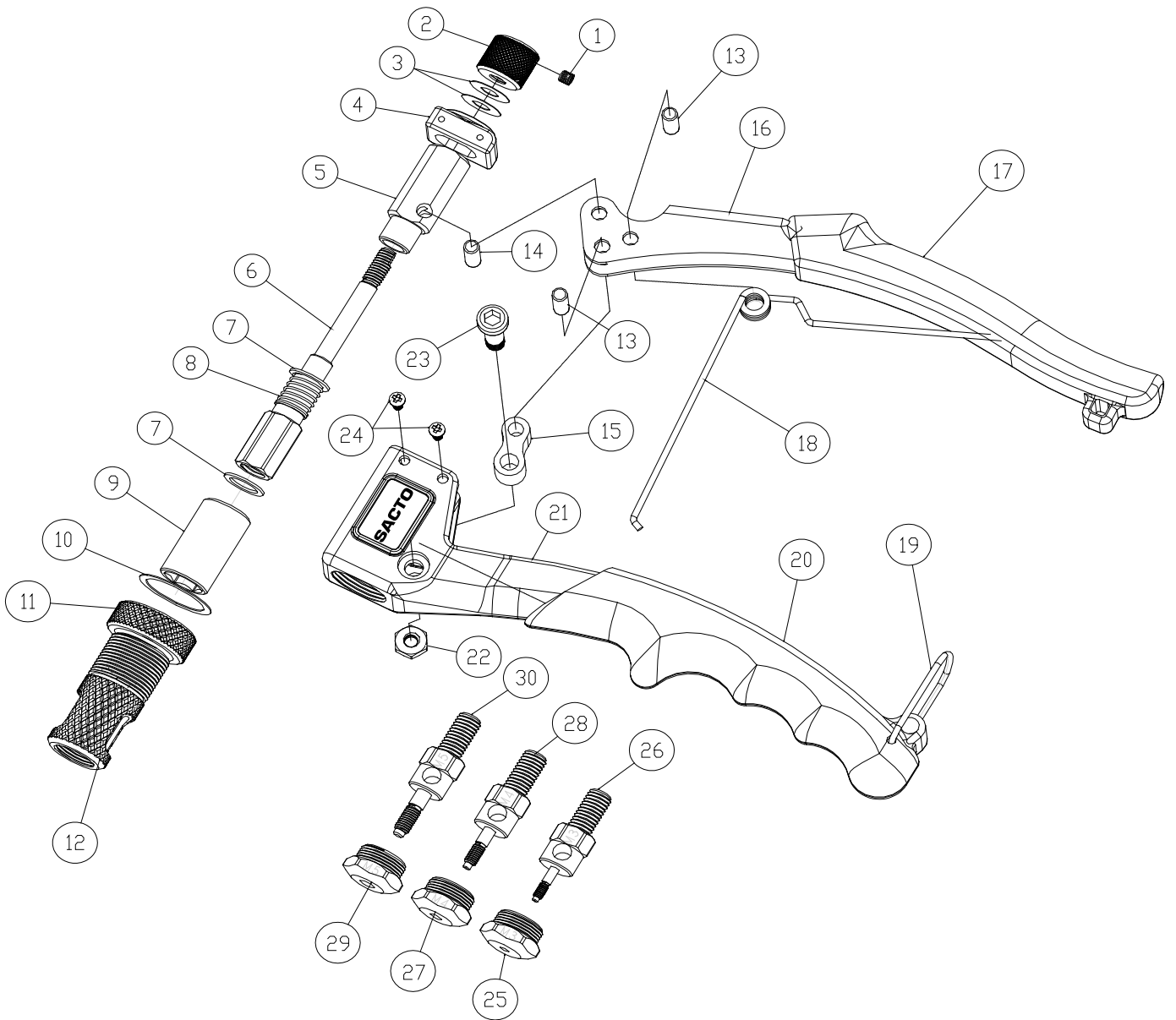

Rivettatrice per inserti filettati con tiranti da M3-M4-M5

Tool for threaded inserts M3-M4-M5

Handwerkzeug für Blindnietmuttern M3-M4-M5



<b>PESO - WEIGHT - GEWICHT</b>	kg 0,560
<b>LUNGHEZZA - LENGHT - GESAMTLANGE</b>	mm 250

RIVETTI BLIND RIVETS BLINDNIETEN	ALLUMINIO ALUMINIUM ALUMINIUM	ACCIAIO STEEL STAHL	INOX INOX INOX
M3	•	•	•
M4	•	•	•
M5	•	•	•

POS.	COD.	QT.	DESCRIZIONE	DENOMINATION	PARTS LIST	BEZEICHNUNG	€ cad.
1	10442	1	Leva inferiore	Corps	Pliers body	Zangenschaft	16.50
2	10055	1	Leva superiore	Levier	Pliers lever	Hebelgriff	7.20
3	510059	1	Perno	Axe	Pin	Bolzen	2.00
4	10179	2	Spina elastica	Goupille	Spring pin	Spannhulse	1.50
5	10181 M3	1	Testa M3	Tete	Head	Kopfteil	10.00
6	10181 M4	1	Testa M4	Tete	Head	Kopfteil	10.00
7	10181 M5	1	Testa M5	Tete	Head	Kopfteil	10.00
8	10187	1	Cannotto	Douille	Barrel	Hulse	14.50
9	10222	1	Coppia impugn.	Poignee	Handle Grip	Griff	2.60
10	10232	1	Anello elastico	Circlips	Seeger ring	Seeger ring	0.60
11	10443 M3	1	Tirante M3	Tirant	Tie Rod	Zugbolzen	22.00
12	10443 M4	1	Tirante M4	Tirant	Tie Rod	Zugbolzen	22.00
13	10443 M5	1	Tirante M5	Tirant	Tie Rod	Zugbolzen	22.00
14	10593	1	Ghiera regolazione	Embout	Ring Nut	Nut Mutter	13.00
15	10594	1	Molla torsione	Ressort	Spring	Feder	3.00
16	10595	1	Perno	Axe	Pin	Stiff	2.20

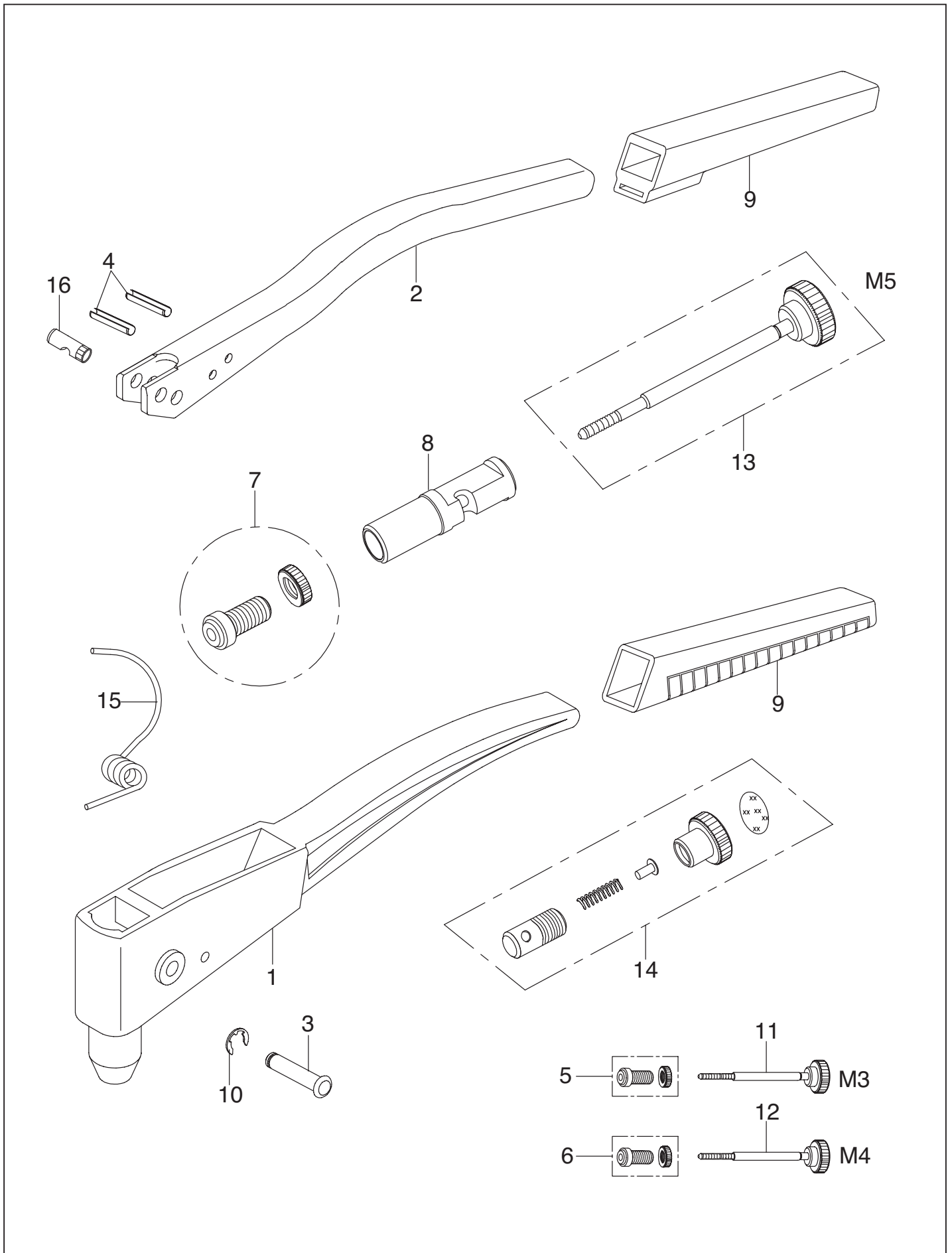

Rivettatrice per inserti filettati con tiranti da M3-M4-M5-M6

Tool for threaded inserts M3-M4-M5-M6

Handwerkzeug für Blindnietmuttern M3-M4-M5-M6

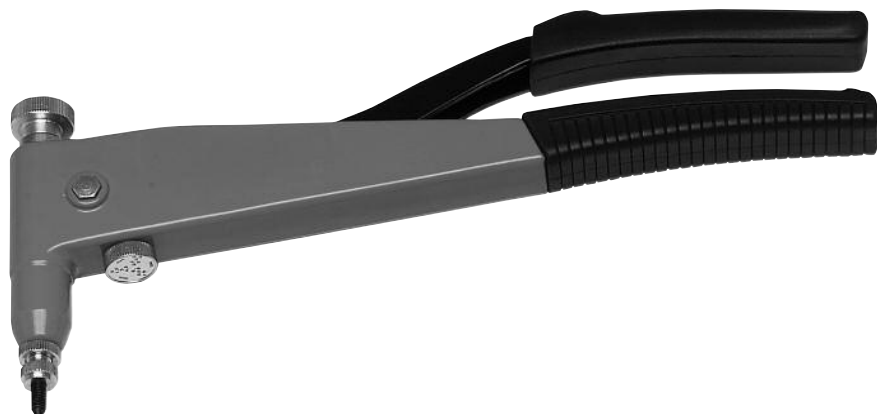

<b>PESO - WEIGHT - GEWICHT</b>	kg 1,100
<b>LUNGHEZZA - LENGHT - GESAMTLANGE</b>	mm 340

RIVETTI BLIND RIVETS BLINDNIETEN	ALLUMINIO ALUMINIUM ALUMINIUM	ACCIAIO STEEL STAHL	INOX INOX INOX
M3	•	•	•
M4	•	•	•
M5	•	•	•
M6	•	•	•

POS.	COD.	QT.	DESCRIZIONE	DENOMINATION	PARTS LIST	BEZEICHNUNG	€ cad.
1	10069	1	Molla torsione	Ressort	Spring	Feder	1.50
2	10075	1	Coppia impugnatura	Poignée	Handle Grip	Griff	2.70
3	10079	1	Perno Ø 7	Axe	Pin	Bolzen	1.70
4	10077	1	Leva superiore	Levier	Pliers lever	Hebelgriff	8.60
5	10089	1	Leva inferiore	Corps	Pliers body	Zangenschaft	25.00
6	10179	2	Spina elasticca	Goupille	Spring pin	Spannhülse	1.50
7	10181 M3	1	Testa M3	Tête	Head	Kopfteil	10.00
8	10181 M4	1	Testa M4	Tête	Head	Kopfteil	10.00
9	10181 M5	1	Testa M5	Tête	Head	Kopfteil	10.00
10	10181 M6	1	Testa M6	Tête	Head	Kopfteil	10.00
11	10184	1	Ghiera regolazione	Embout	Ring Nut	Nut Mutter	4.00
12	10186	1	Perno	Axe	Pin	Stift	1.60
13	10188 M3	1	Tirante M3	Tirant	Tie Rod	Zugbolzen	22.00
14	10188 M4	1	Tirante M4	Tirant	Tie Rod	Zugbolzen	22.00
15	10188 M5	1	Tirante M5	Tirant	Tie Rod	Zugbolzen	22.00
16	10188 M6	1	Tirante M6	Tirant	Tie Rod	Zugbolzen	22.00
17	10191	1	Cannotto	Douille	Barrel	Hülse	14.60
18	10587	1	Anello elastico	Circlips	Seeger ring	Seeger Ring	1.00

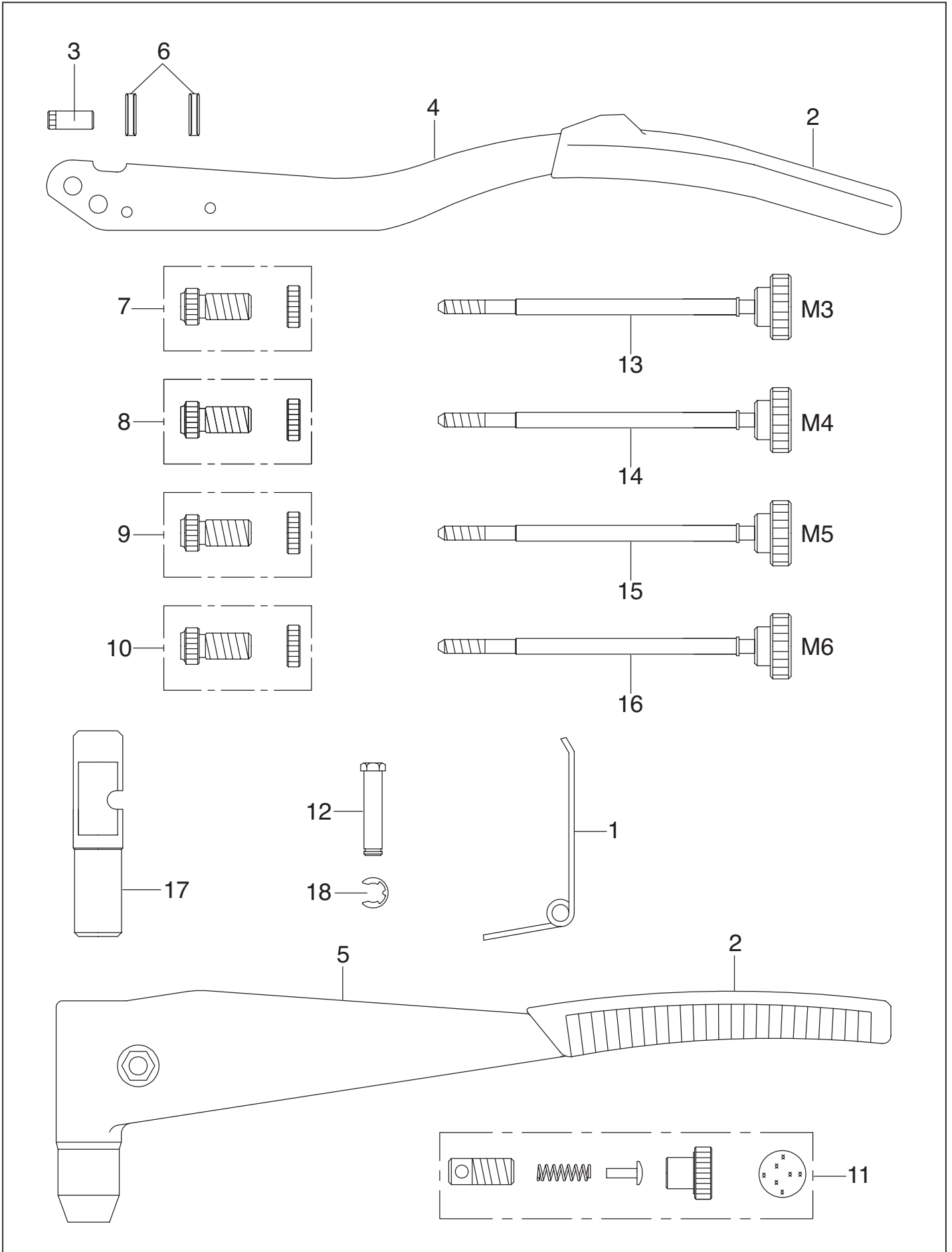



Rivettatrice per inserti filettati M3-M4-M5-M6-M8-M10

Tool for threaded inserts M3-M4-M5-M6-M8-M10

Handwerkzeug für Blindnietmuttern M3-M4-M5-M6-M8-M10

<b>PESO - WEIGHT - GEWICHT</b>	kg 4,500
<b>DIMENSIONI - SIZE - DIMENSION</b>	mm 550x200x60

RIVETTI BLIND RIVETS BLINDNIETEN	ALLUMINIO ALUMINIUM	ACCIAIO STEEL STAHL	INOX INOX INOX
M3	•	•	•
M4	•	•	•
M5	•	•	•
M6	•	•	•
M8	•	•	•
M10	•	•	•

POS.	COD.	QT.	DESCRIZIONE	DENOMINATION	PARTS LIST	BEZEICHNUNG	€ cad.
1	10035	2	Leve lunghe	Bras de levier	Handle	Hebelarm	12.60
2	10048	8	Rondella ottone Ø 6	Rondelle	Washer	Scheibe	1.00
3	10095	1	Corpo	Corps	Body	Gehäuse	16.60
4	10112	2	Impugnatura sogomata	Poignée	Handle Grip	Griff	4.40
5	10115	4	Leve piccole	Bielle	Link	Scherenarm	5.40
6	10117	6	Rondella Ø 5 zincata	Rondelle	Washer	Scheibe	1.00
7	10118	6	Dado M5	Ecrou	Nut	Mutter	4.00
8	10119	2	Vite	Vis	Screw	Schraube	0.50
9	10120	4	Perno Ø 6x30	Axe	Pin	Stift	3.30
10	10121	2	Ammortizzatore	Amortisseur	Damper	Stossdämfer	2.90
11	10122	2	Perno Ø 6x36	Axe	Pin	Stift	1.70
12	10193M3	1	Testa M3	Tête	Head	Kopfteil	15.80
13	10193M4	1	Testa M4	Tête	Head	Kopfteil	15.80
14	10193M5	1	Testa M5	Tête	Head	Kopfteil	15.80
15	10193M6	1	Testa M6	Tête	Head	Kopfteil	15.80
16	10193M8	1	Testa M8	Tête	Head	Kopfteil	15.80
17	10193M10	1	Testa M10	Tête	Head	Kopfteil	15.80
18	10195	1	Bussola	Embout	Ring Nut	Nut Mutter	10.40
19	10196M3	1	Tirante M3	Tirant	Tie Rod	Zugbolzen	12.40
20	10196 M4	1	Tirante M4	Tirant	Tie Rod	Zugbolzen	12.40
21	10196 M5	1	Tirante M5	Tirant	Tie Rod	Zugbolzen	12.40
22	10196 M6	1	Tirante M6	Tirant	Tie Rod	Zugbolzen	12.40
23	10196 M8	1	Tirante M8	Tirant	Tie Rod	Zugbolzen	12.40
24	10196 M10	1	Tirante M10	Tirant	Tie Rod	Zugbolzen	12.40
25	10197	1	Cannotto	Douille	Barrel	Hülse	10.00
26	10198	1	Asta	Tirant	Main shaft	Zug stange	11.00
27	10199	1	Ghiera regolazione	Embout	Ring Nut	Nut Mutter	8.00
28	10200	1	Asta	Axe	Main shaft	Zug stange	7.40
29	10206	1	Gruppo avvitatore	Visseur	Body	Gehäuse	106.00
30	10210	1	Snodo	Plaquette	Power coupling plate	Zug teil platte	13.50
31	10599	1	Chiave	Clé	Spanner	Schlüsser	8.00
32	10623	1	Ghiera regolazione	Embout	Ring Nut	Nut Mutter	4.00
33	10194	1	Ghiera regolazione	Embout	Ring Nut	Nut Mutter	5.60

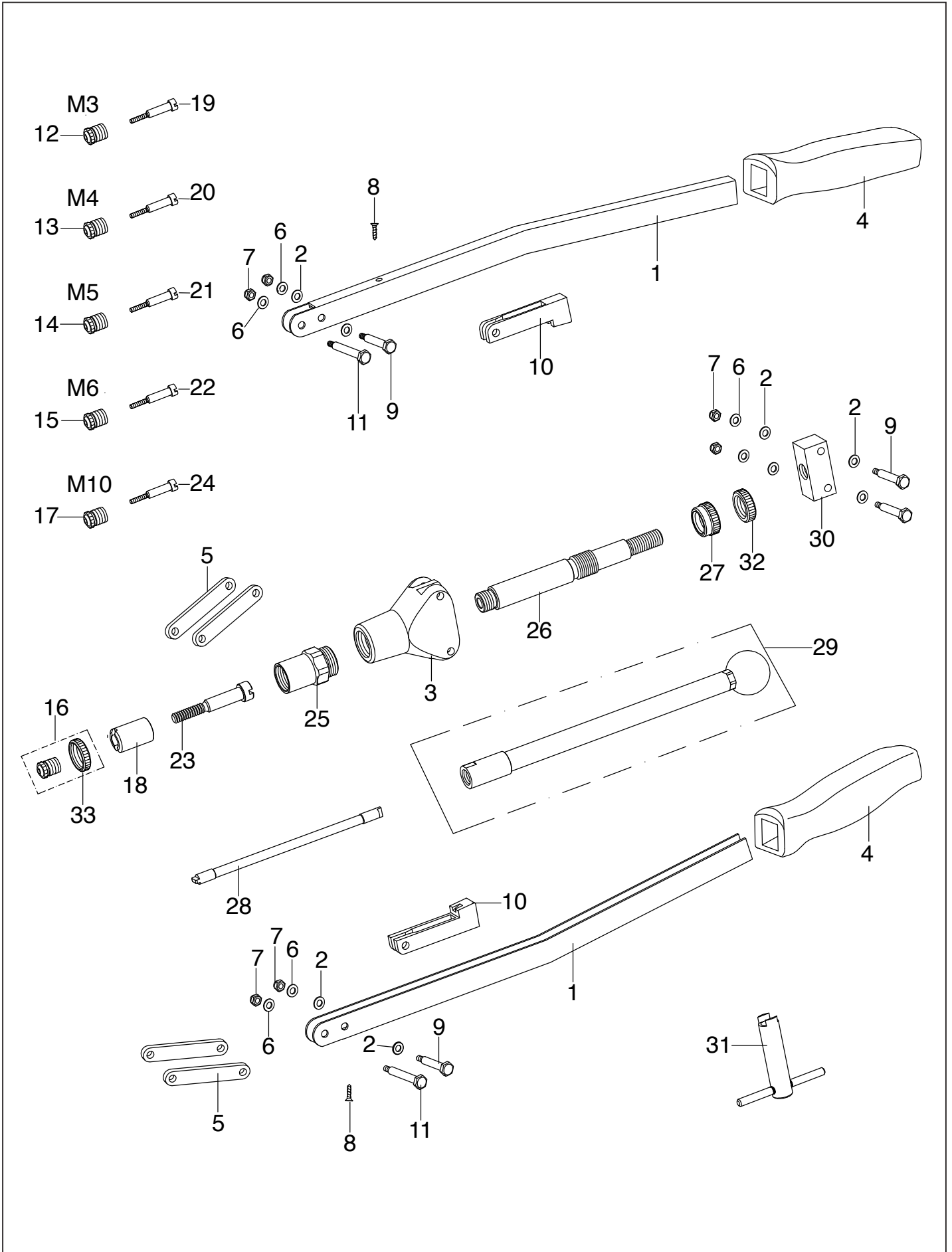



Rivettatrice per inserti filettati M6-M8-M10-M12

Tool for threaded inserts M6-M8-M10-M12

Handwerkzeug für Blindnietmuttern M6-M8-M10-M12

<b>PESO - WEIGHT - GEWICHT</b>	kg 4,500
<b>DIMENSIONI - SIZE - DIMENSION</b>	mm 550x200x60

RIVETTI BLIND RIVETS BLINDNIETEN	ALLUMINIO ALUMINIUM ALUMINIUM	ACCIAIO STEEL STAHL	INOX INOX INOX
M6	•	•	•
M8	•	•	•
M10	•	•	•
M12	•	•	•

POS.	COD.	QT.	DESCRIZIONE	DENOMINATION	PARTS LIST	BEZEICHNUNG	€ cad.
1	10035	2	Leve lunghe	Bras de levier	Handle	Hebelarm	12,60
2	10048	8	Rondella ottone Ø 6	Rondelle	Washer	Scheibe	1,00
3	10096	1	Corpo	Corps	Body	Gehäuse	16,60
4	10105	1	Cannotto	Douille	Barel	H_ise	10,00
5	10106	1	Ghiera	Embout	Ring Nut	Nut Mutter	8,00
6	10107 M6	1	Testa M6	Tête	Head	Kopfteil	15,80
7	10107 M8	1	Testa M8	Tête	Head	Kopfteil	15,80
8	10107 M10	1	Testa M10	Tête	Head	Kopfteil	15,80
9	10107 M12	1	Testa M12	Tête	Head	Kopfteil	15,80
10	10108 M6	1	Tirante M6	Tirant	Tie Rod	Zugblzen	12,40
11	10108 M8	1	Tirante M8	Tirant	Tie Rod	Zugblzen	12,40
12	10108 M10	1	Tirante M10	Tirant	Tie Rod	Zugblzen	12,40
13	10108 M12	1	Tirante M12	Tirant	Tie Rod	Zugblzen	12,40
14	10112	2	Impugnatura sagomata	Poignée	Handle Grip	Griff	4,40
15	10115	4	Leve piccole	Bielle	Links	Scherenarm	5,40
16	10117	6	Rondella Ø 5 zincata	Rondelle	Washer	Scheibe	0,70
17	10118	6	Dado M5 autobloccante	Ecrou	Nut	Mutter	4,00
18	10119	2	Vite TS 2.9 X 13 ZB	Vis	Screw	Schraube	0,30
19	10120	4	Perno Ø 6 X 30	Axe	Pin	Stift	3,30
20	10121	2	Ammortizzatore	Amortisseur	Damper	Stossdämfer	3,90
21	10122	2	Perno Ø 6 X 36	Axe	Pin	Stift	1,70
22	10192	1	Asta	Tirant	Main shaft	Zug stange	11,00
23	10199	1	Ghiera regolazione	Embout	Ring Nut	Nut Mutter	8,00
24	10200	1	Asta avvitatore	Axe	Main shaft	Zug stange	7,40
25	10210	1	Snodo	Plaquette	Power coupling plate	Zug teil platte	13,50
26	10219	1	Perno in ferro	Axe	Pin	Stift	3,30
27	10220	1	Grano M6 X 16	Grain	Grub screw	Schraube	1,00
28	10221	1	Pomolo avvitatore alluminio	Poignée	Knob	Knopf	18,00
29	10223	2	Distanziale nylon	Entretoise nylon	Nylon spacer	Nylon Zwischenteil	3,00
30	10224	1	Bussola	Embout	Ring Nut	Nut Mutter	6,00
31	10225	1	Bussola porta tiranti	Embout	Ring Nut	Nut Mutter	8,00
32	10599	1	Chiave	Clé	Spanner	Schlüssel	8,00
33	10623	1	Ghiera regolazione	Embout	G Nut	Nut Mutter	8,00

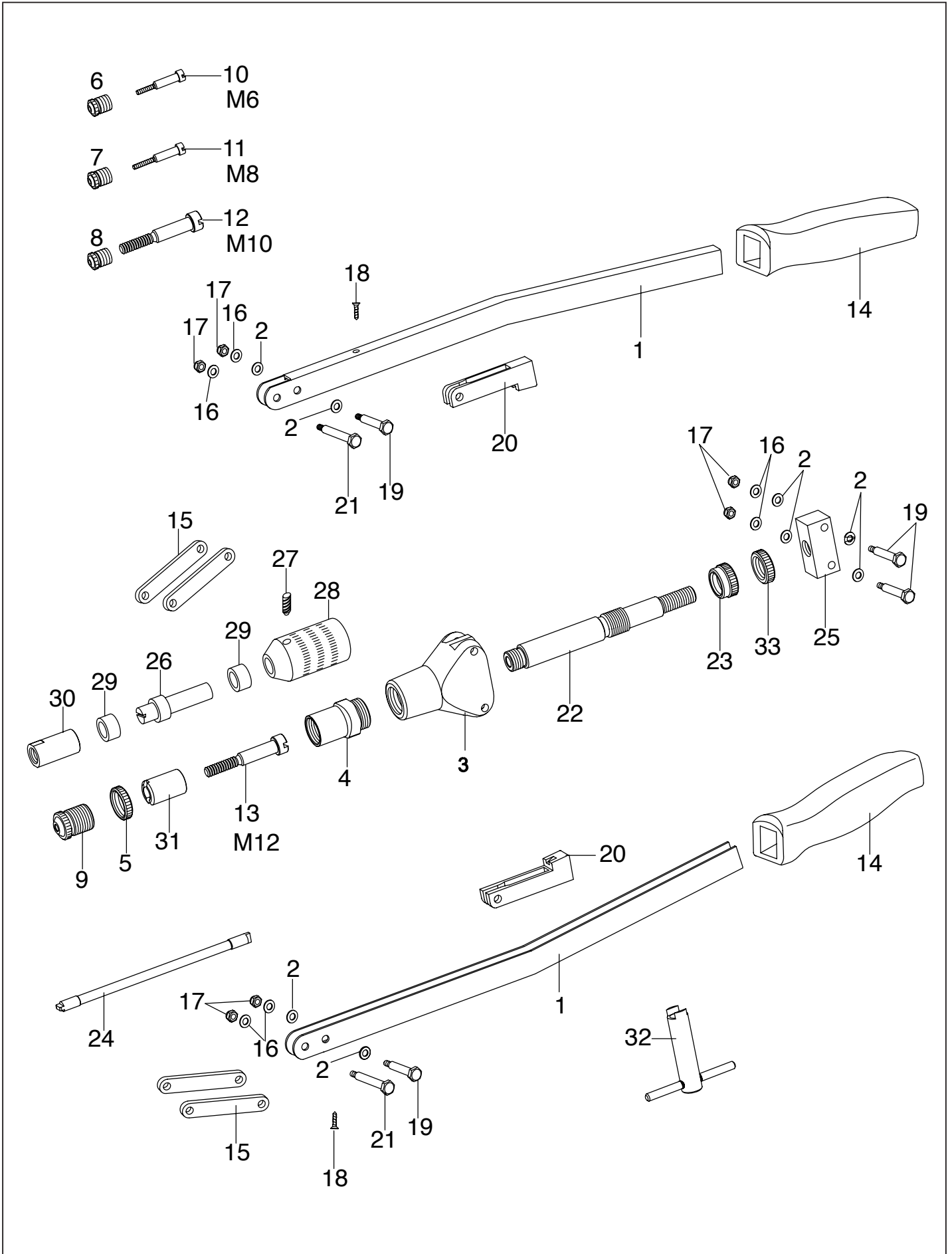

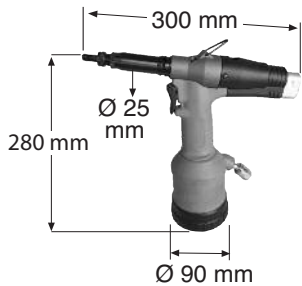
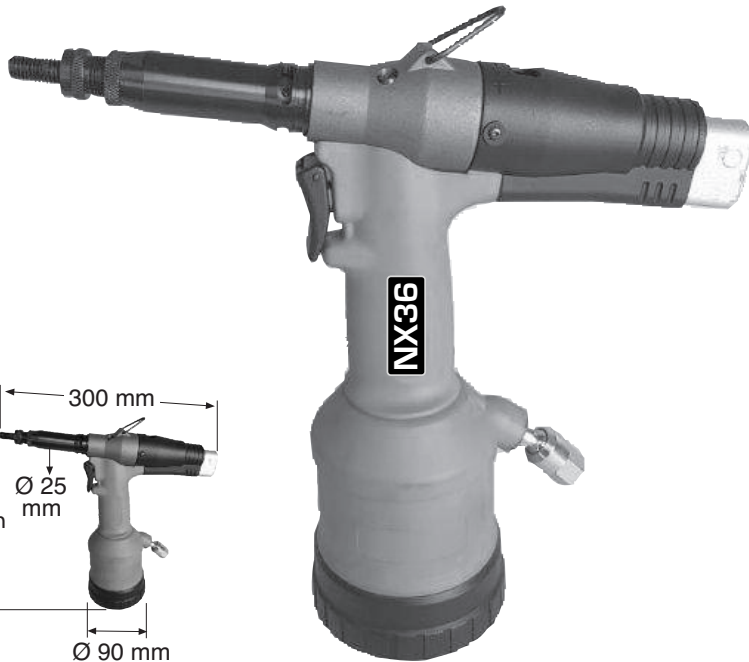

Rivettatrice oleopneumatica per inserti filettati M3-M10.  
 Hydropneumatic tool for threaded inserts M3-M10.  
 Ölpneumatisches Werkzeug für Blindnietmuttern M3-M10.

<b>PESO - WEIGHT - GEWICHT</b>	kg 2,0
--------------------------------	--------

RIVETTI BLIND RIVETS BLINDNIETEN	ALLUMINIO ALUMINIUM	ACCIAIO STEEL STAHL	INOX INOX INOX
M3	•	•	•
M4	•	•	•
M5	•	•	•
M6	•	•	•
M8	•	•	•
M10	•	•	•

POS.	COD.	QT.	DESCRIZIONE	DENOMINATION	PARTS LIST	BEZEICHNUNG	€ cad.
1	168110M3	1	Testa M3	Cabeza M3	Head M3	Kopf M4	8,50
1	168110M4	1	Testa M4	Cabeza M4	Head M4	Kopf M5	8,50
1	168110M5	1	Testa M5	Cabeza M5	Head M5	Kopf M5	8,50
1	168110M6	1	Testa M6	Cabeza M6	Head M6	Kopf M6	8,50
1	168110M8	1	Testa M8	Cabeza M8	Head M8	Kopf M8	8,50
1	168110M10	1	Testa M10	Cabeza M10	Head M10	Kopf M10	8,50
2	168111	1	Ghiera	Dado	Nut	Schraubenmutter	6,80
3	168112	1	Cannotto	Cabeza	Nosepiece	Dusenträger	66,00
4	168114	1	Porta tirante	Puerta tirante	Connection base	Drehkupplung	22,00
5	168116M3	1	Adattatore M3	Adaptador M3	Adaptor M3	Ansatz M3	4,20
5	168116M4	1	Adattatore M4	Adaptador M4	Adaptor M4	Ansatz M4	4,20
5	168116M5	1	Adattatore M5	Adaptador M5	Adaptor M5	Ansatz M5	4,20
5	168116M6	1	Adattatore M6	Adaptador M6	Adaptor M6	Ansatz M6	4,20
5	168116M8	1	Adattatore M8	Adaptador M8	Adaptor M8	Ansatz M8	4,20
5	168116M10	1	Adattatore M10	Adaptador M10	Adaptor M10	Ansatz M10	4,20
6	168125M3	1	Tirante M3	Tirante M3	Tie rod M3	Gewindedorn M3	4,80
6	168125M4	1	Tirante M4	Tirante M4	Tie rod M4	Gewindedorn M4	4,80
6	168125M5	1	Tirante M5	Tirante M5	Tie rod M5	Gewindedorn M5	4,80
6	168125M6	1	Tirante M6	Tirante M6	Tie rod M6	Gewindedorn M6	4,80
6	168125M8	1	Tirante M8	Tirante M8	Tie rod M8	Gewindedorn M8	4,80
6	168125M10	1	Tirante M10	Tirante M10	Tie rod M10	Gewindedorn M10	4,80
7	168130M3	1	Riduzione esagonale M3	Reductor Hexagonal M3	Hexagonal reduction M3	Sechskantreduzier M3	4,00
7	168130M4	1	Riduzione esagonale M4	Reductor Hexagonal M4	Hexagonal reduction M4	Sechskantreduzier M4	4,00
7	168130M5	1	Riduzione esagonale M5	Reductor Hexagonal M5	Hexagonal reduction M5	Sechskantreduzier M5	4,00
7	168130M6	1	Riduzione esagonale M6	Reductor Hexagonal M6	Hexagonal reduction M6	Sechskantreduzier M6	4,00
7	168130M8	1	Riduzione esagonale M8	Reductor Hexagonal M8	Hexagonal reduction M8	Sechskantreduzier M8	4,00
7	168130M10	1	Riduzione esagonale M10	Reductor Hexagonal M10	Hexagonal reduction M10	Sechskantreduzier M10	4,00
8	168131	1	O-ring	O-ring	O-ring	O-ring	3,80
9	168132	1	Supporto tirante	Soporte tirante	Spindle tie road	Lager	44,00
10	168133	1	Dado	Dado	Nut - closure	Schraubenmutter	12,70
11	168134	1	Ghiera	Soporte dado	Reatining nut	Lager schraubenmutter	15,40
12	168135	1	Guarnizione	Guarnición	Gasket	Dichtung	25,80
13	168136	1	Corpo idraulico	Cuerpo	Hydraulic body	Hydraulikgehäuse	152,33
14	168137	1	O-ring	O-ring	O-ring	O-ring	3,80
15	168138	1	Vite tappo	Tornillo tapón	Tapping screw	Schraub Verschluss	8,00
16	168139	1	Gancio	Gancho	Hook	Aufzuhaken	2,60
17	168140	4	O-ring	O-ring	O-ring	O-ring	2,20
18	168141	2	Anello	Anillo	Leading ring	Führungsring	7,50
19	168142	1	Vite	Tornillo	Screw	Schraub	2,20
20	168143	1	Guarnizione	Sello anterior	Front seal	Manschette	29,50
21	168144	1	Pistone idraulico	Pistón hydraulic	Hydraulic piston	Hydraulikkolben	118,80
22	168145	1	Molla	Resorte	Spring	Feder	12,60
23	168146	1	Regolazione corsa	Anillo resorte	Leading spring	Führungsring	50,80
24	168147	1	Distanziale	Distanciador	Spacer	Distanzstück	1,10
25	168148	1	Innesto femmina	Cruceta	Piston pin	Kolbenbolzen	33,00
26	168149	1	Innesto maschio	Cruceta	Piston pin	Kolbenbolzen	22,00
27	168150	1	Molla	Resorte	Spring	Feder	1,00
28	168151	1	Ghiera	Conectador	Connector	Verbinder	33,70
29	168152	1	Motore	Motor	Motor	Motor	660,00
30	168153	1	Canotto porta motore	Porta motor	Motor holding case	Motorhalter	66,00
31	168154	1	Perno	Pernio	Pin	Ventilstifte	6,60
32	168155	1	Rondella nylon	Arandela	Naylon washer	Nailon Scheibe	2,20
33	168156	1	Molla	Resorte	Spring	Feder	2,20
34	168157	1	O-ring	O-ring	O-ring	O-ring	2,20
35	168158	1	Vite	Tornillo	Screw	Schraub	6,60
36	168159	2	Rondella rame	Arandela de cobre	Copper washer	Kupfer Scheibe	7,50
37	168160	2	Tubo aria d. 5	Tubo aire	Air tube	Luftrohr	1,30

POS.	COD.	QT.	DESCRIZIONE	DENOMINATION	PARTS LIST	BEZEICHNUNG	€ cad.
38	168161	4	Vite M3	Tornillo	Screw	Schraub	2,20
39	168162	4	Vite M5	Tornillo	Screw	Schraub	2,20
40	168163	1	Perno valvola	Pernio válvula	Pin valve	Ventilstifte	8,45
41	168164	2	O-ring	O-ring	O-ring	O-ring	3,70
42	168165	3	O-ring	O-ring	O-ring	O-ring	4,20
43	168166	3	Ghiera guida	Virola principal	Principal ring nut	Führungsring	33,80
44	168167	1	Valvola	Válvula	Valve	Ventil	38,00
45	168168B	1	Perno valvola	Pernio válvula	Pin valve	Ventilstifte	38,00
46	168169	1	Dado valvola	Anillo válvula	Leading valve	Führungsring	33,00
47	168170	1	Grilletto	Gatillo	Trigger	Drucktaster	6,80
48	168171	1	Spina	Espina	Pin	Verdichtung	1,70
49	168172	2	O-ring	O-ring	O-ring	O-ring	2,20
50	168173B	1	Cilindro oleodinamico	Tube	Oil tube	Rohr	59,40
53	168176B	1	Cilindro aria	Cilindro	Cylinder	Pneumatikzylinder	35,00
54	168177B	2	Ghiera inferiore	Virola inferior	Lower ring nut	Unterring	8,00
55	168178	4	Raccordo M6	Distanciador	Spacer	Zwischenteil	3,08
56	168179	2	Tube aria d. 6	Tube	Tube	Rohr	1,40
57	168180B	1	Tube aria	Tube	Tube	Rohr	20,00
59	168182B	1	Perno	Pernio	Pin	Ventilstifte	12,00
61	168184B	1	O-ring	O-ring	O-ring	O-ring	7,00
62	168185B	1	Pistone pneumatico	Pistón neumático	Pneumatic piston	Pneumatikkolben	35,00
63	168186B	1	Vite	Tornillo	Screw	Schraub	2,20
64	168187B	1	O-ring	O-ring	O-ring	O-ring	4,22
66	168189B	1	Fondello protezione	Cobertura	Covering	Deckung	26,00
70	168193B	2	Vite M4	Tornillo	Screw	Schraub	2,55
71	168194B	2	Coppia impugnature	Empunadura	Handle	Hebelam	26,00
73	168195	4	Vite	Tornillo	Screw	Schraub	0,30
74	168196	1	Protezione	Protección	Protection	Schutzscheibe	12,67
75	168197	2	Vite	Tornillo	Screw	Schraub	2,50
76	168198	1	Attacco aria	Ataque	Air connector	Deckung	12,80
77	168200	1	O-ring	O-ring	O-ring	O-ring	5,00
78	168201	1	Piastra	Placa	Clamp plate	Lager	5,00
79	168203	1	Vite tappo	Tornillo	Tapping screw	Schraub	2,00
80	168204	1	Guarnizione	Junta	Lip seal	Dichtung	11,00
81	168205	1	Pistoncino	Pistón	Oil tube piston	Kolben	8,00
82	168206	1	O-ring	O-ring	O-ring	O-ring	4,00
83	168207	1	Guarnizione	Junta	Piston ring	Dichtung	3,80
84	168208	1	Guarnizione	Junta	Washer	Dichtung	5,00
85	168209	1	Anello tenuta	Anillo	Retaining ring	Führungsring	5,00
86	168210	1	Guarnizione	Junta	Washer	Dichtung	6,00
87	168211	1	Cilindro	Cilindro	Plastic cylinder	Zylinder	62,00
88	168212	1	Distanziale	Espaciador	Spacer	Distanzstück	4,00
89	168213	1	Fondello cilindro	Cobertura	Covering	Deckung	4,00
10819		1	Siringa	Jeringa	Syringe	Spritze	
10820		1	Bottiglietta olio 35 ml	Botella	Oil bottle	Öl Flasche	
10821		1	Chiave brugola	Allen	Allen screw	Innensechskantschlüssel	

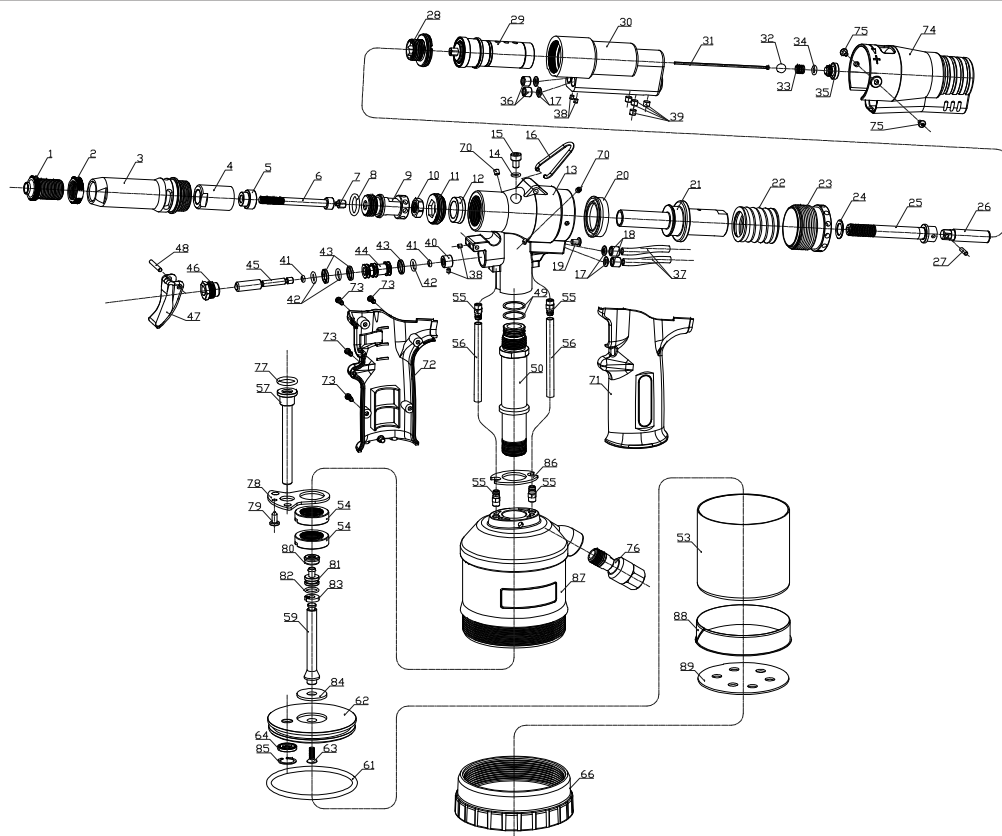



Rivettatrice oleopneumatica per inserti filettati M6÷M12.  
Riveteuse oléopneumatique

Hydropneumatic tool for threaded inserts M6÷M12.

Öl-pneumatisches Werkzeug für Blindnietmuttern M6÷M12.

<b>PESO - WEIGHT - GEWICHT</b>	kg 2,5
--------------------------------	--------

M	ALLUMINIO ALUMINIUM ALUMINIUM	ACCIAIO STEEL STAHL	INOX INOX INOX
M6	•	•	•
M8	•	•	•
M10	•	•	•
M12	•	•	•

POS.	COD.	QT.	DESCRIZIONE	DENOMINATION	PARTS LIST	BEZEICHNUNG	€ cad.
1	168110M4	1	Testa M4	Tête M4	Head M4	Kopf M5	8,50
1	168110M5	1	Testa M5	Tête M5	Head M5	Kopf M5	8,50
1	168110M6	1	Testa M6	Tête M6	Head M6	Kopf M6	8,50
1	168110M8	1	Testa M8	Tête M8	Head M8	Kopf M8	8,50
1	168110M10	1	Testa M10	Tête M10	Head M10	Kopf M10	8,50
1	168110M12	1	Testa M12	Tête M12	Head M12	Kopf M12	8,50
2	168111	1	Ghiera	Embout	Nut	Schraubenmutter	6,80
3	168112	1	Cannotto	Canne	Nosepiece	Duseneträger	66,00
4	168114	1	Porta tirante	Porte tirant	Connection base	Drehkupplung	22,00
5	168116M4	1	Adattatore M4	Adaptateur M4	Adaptor M4	Ansatz M4	4,20
5	168116M5	1	Adattatore M5	Adaptateur M5	Adaptor M5	Ansatz M5	4,20
5	168116M6	1	Adattatore M6	Adaptateur M6	Adaptor M6	Ansatz M6	4,20
5	168116M8	1	Adattatore M8	Adaptateur M8	Adaptor M8	Ansatz M8	4,20
5	168116M10	1	Adattatore M10	Adaptateur M10	Adaptor M10	Ansatz M10	4,20
6	168125M4	1	Tirante M4	Tirant M4	Tie rod M4	Gewindedorn M4	4,80
6	168125M5	1	Tirante M5	Tirant M5	Tie rod M5	Gewindedorn M5	4,80
6	168125M6	1	Tirante M6	Tirant M6	Tie rod M6	Gewindedorn M6	4,80
6	168125M8	1	Tirante M8	Tirant M8	Tie rod M8	Gewindedorn M8	4,80
6	168125M10	1	Tirante M10	Tirant M10	Tie rod M10	Gewindedorn M10	4,80
6	168125M12	1	Tirante M12	Tirant M12	Tie rod M12	Gewindedorn M12	4,80
7	168130M4	1	Riduzione esagonale M4	Reducteur M4	Hexagoanl reduction M4	Sechskantreduzier M4	4,00
7	168130M5	1	Riduzione esagonale M5	Reducteur M5	Hexagoanl reduction M5	Sechskantreduzier M5	4,00
7	168130M6	1	Riduzione esagonale M6	Reducteur M6	Hexagoanl reduction M6	Sechskantreduzier M6	4,00
7	168130M8	1	Riduzione esagonale M8	Reducteur M8	Hexagoanl reduction M8	Sechskantreduzier M8	4,00
7	168130M10	1	Riduzione esagonale M10	Reducteur M10	Hexagoanl reduction M10	Sechskantreduzier M10	4,00
7	168130M12	1	Riduzione esagonale M12	Reducteur M12	Hexagoanl reduction M12	Sechskantreduzier M12	4,00
7	10607	1	O ring	O ring	O ring	O ring	5,00
8	10608M10	1	Supporto M10	Support M10	Support M10	Lager M10	40,00
9	10609M10	1	Ghiera tirante M10	Ecrou tirant M10	Nut M10	Nutmutter M10	16,00
10	10610	1	Supporto canotto	Support canne	Support	Lager	26,00
11	10611	1	O ring	O ring	O ring	O ring	2,50
14	10651M10	1	Pistone idraulico completo M10	Piston hydraulique complète M10	Complete hydraulic piston M10	Hydraulikkolben komplett M10	640,00
15	10652	1	O-ring 18/2.2, asta pistone idraulico	Joint torique 18/2.2, piston hydraulique tringle	O-ring 18/2.2, rod hydraulic piston	O-ring 18/2.2, hydraulische kolbenstange	4,00
16	10653	1	Sigillo ant. 26/18-6, asta pistone idraulico	Cachet frontale 26/18-6, piston hydraulique tringle	Front seal 26/18-6, rod hydraulic piston	Manschette 26/18-6, hydraul. kolbenstange	25,00
17	10654	1	Anello ammortizzatore, pistone idraulico	Anneau d'étouffoir, piston hydraulique	Damper ring, hydraulic piston	Stoßring hydraulikkolben	28,60
18	10655	1	Vite tappo m 5x8	Vis taraudeuse M5x8	Tapping screw M5x8	Schraub Verschluß M5x8	2,00
19	10656	1	O-ring 4/1.5	Joint torique 4/1.5	O-ring 4/1.5	O-ring 4/1.5	4,80
20	10657	1	Gancio	Crochet	Hook	Haken	2,60
21	10658	1	Corpo idraulico	Corps hydraulique	Hydraulic body	Hydraulikgehäuse	380,00
22	10659	1	Sigillo anteriore 34/22-9.4, pistone idraulico	Cachet frontale 34/22-9.4, piston hydraulique	Front seal 34/22-9.4, hydraulic piston	Manschette 34/22-9.4 hydraulikkolben	25,00
23	10660	1	Anello di guida 34/22/2.5 teflon	Anneau avant 34/22/2.5 téflon	Leading ring 34/22/2.5 teflon	Führungsring 34/22/2.5 teflon	6,00
24	10661	1	O-ring 28/3, pistone idraulico	Joint torique 28/3, piston hydraulique	O-ring 28/3, hydraulic piston	O-ring 28/3, hydraulikkolben	6,00
25	10662	1	O-ring 36/2, tubo di avvitamento anteriore	Joint torique 36/2, tube de rotation frontale	O-ring 36/2, front-end spin tube	O-ring 36/2, hintere verschraubung	6,00
26	10663	1	Cannotto porta motore	Porte motor	Motor holding case	Motorhalter	36,00
27	10664	1	Protezione contenitore	Protection de corp	Body protectoin	Schutzscheibe	11,20
28	10665	1	Perno cilindrico 4,0x10	Goupille cylindrique 4,0x10	Cylindrical pin 4,0x10	Zylinderstifte 4,0x10	3,00
29	10666	1	Molla	Ressort	Spring	Feder	48,00
30	10667	1	Molla di compressione	Corp de compression	Compression spring	Druckfeder	6,40
31	10669	1	Tubo di avvitamento anteriore	tube de rotation frontale	Front-end spin tube	Hintere verschraubung	45,00
32	10670	1	Anello per spina di compressione	Anneau pour Goupille de compression	Ring for compression pin	Ring für druckfeder	3,60
33	10671	1	Silenziatore	Silencieux	Silencer	Schalldämpfer	5,00
34	10672	1	Tasto di avvio	Poussoir start	Starting button	Drucktaster	2,40
35	10673	1	Sigillo ant. 22/12-7, asta pistone pneum.	Cachet frontal22/12-7, piston hydraulique tringle	Front.end seal 22/12-7, rod pneum. piston	Manschette 22/12-7 pneum. kolbenstange	28,80
36	10674	1	O.R.	O.R.	O.R.	O.R.	5,60
37	10675	1	Ghiera inferiore	Ecrou à œil inférieur	Lower ring nut	Bodenring	24,20
38	10676	1	Pistone pneumatico	Piston pneumatique	Pneumatic piston	Pneumatikkolben	84,00
39	10677	1	Cilindro pneumatico	Cylindre pneumatique	Pneumatic cylinder	Pneumatikzylinder	164,00

POS.	COD.	QT.	DESCRIZIONE	DENOMINATION	PARTS LIST	BEZEICHNUNG	€ cad.
40	10678	1	Ghiera di copertura	Ecrou à œil couverture	Covering ring nut	Verchlußplatte	86,50
41	10679	1	O-ring 14/2	Joint torique 14/2	O-ring 14/2	O-ring 14/2	12,00
42	10680	1	O-ring 89/4, pistone pneumatico	Joint torique 89/4, piston hydraulique	O-ring 89/4, pneumatic piston	O-ring 89/4 pneumatikkolben	12,00
43	10681	1	Attacco presa pressione	Pièce de fixation pression	Pressure fastening	Verbindungshülse für manometer	9,60
44	10682	1	O-ring 10/1.5	Joint torique 10/1.5	O-ring 10/1.5	O-ring 10/1.5	3,60
45	10683	1	Presa pressione	Accouplement pression	Pressure engagement	Manometer	30,00
46	10684	1	Indicatore livello olio	Indicateur niveau huile	Oil level indicator	Ölstandanzeiger	38,80
47	10685	1	O-ring 10/1.5	Joint torique 10/1.5	O-ring 10/1.5	O-ring 10/1.5	4,00
48	10686	1	Valvola rilievo pressione	Evaluation pression soupape	Valve pressure survey	Überdruckventil	29,00
49	10687	1	Valvola di regolazione pressione	Soupape régulation er pression	Regulation and pressure valve	Druckregelventig	25,00
50	10688	2	O-ring 18/1.5	Joint torique 18/1.5	O-ring 18/1.5	O-ring 18/1.5	4,00
51	10689	1	Ghiera di ritenuta 6 din 471	Ecrou à œil 6din 471	Ring nut 6 din 471	Sicherungsring 6 din 471	6,40
52	10690	1	Vite regolazione pressione	Poussoir régulation er pression	Regulation and pressure button	Einstellschraube druck	9,00
53	10691	1	Copertura	Couverture	Covering	Abschirmung	4,40
54	10692	1	Ghiera di ritenuta	Ecrou à œil	Ring nut	Sicherungsring	6,40
55	10693	1	Ghiera inferiore	Ecrou à œil inferieur	Lower ring nut	Bodenring	25,00
56	10694	1	Attacco connessione 90°	Tringlerie connexion 90°	90° connection linkage	Drehkupplung 90°	48,00
57	10695	2	Dado di connessione	Courseur de connexion	Connection nut	Führungsbolzen	16,00
58	10696	2	Rondella in rame per dado di connessione	Rondelle en cuivre pour curseur de connexion	Copper washer for connection nut	Kupfer scheibe	2,00
59	10697	2	Perno tappo m6 per dado di connessione	Tête tige m6 pour curseur de connexion	Pin cap m6 for connection nut	Überwurfmutter m6	3,00
60	10698	1	Perno valvola dado inferiore	Tige soupape curseur inferieur	Pin valve lower nut	Bolzen unter ventilstange	11,00
61	10699	1	O-ring 4/2, perno valvola	Joint torique 4/2, soupape tige	O-ring 4/2, pin valve	O-ring 4/2, ventilstange	3,60
62	10800	1	Valvola per valvola ad ago	Soupape pour pointeau	Valve for needle valve	Buchse für einstellventil	32,00
63	10801	1	Scarico	Décharge	Unloading	Schalldämpfer	4,00
64	10802	2	O-ring 4/2	Joint torique 4/2	O-ring 4/2	O-ring 4/2	3,60
65	10803	4	Vite	Vis	Screw	Schraube	6,40
66	10804	3	O-ring 10/2	Joint torique 10/2	O-ring 10/2	O-ring 10/2	3,60
67	10805	1	Perno valvola	Soupape tige	Pin valve	Ventilstange	38,20
68	10806	1	Perno cilindrico 3,0x20	Tige cylindrique 3,0x20	Cylindrical pin 3,0x20	Zylinderstifte 3,0x20	4,00
69	10807	1	Grilletto eccentrico	Déclencheur excentrique	Eccentric trigger	Exzentrische drucktaster	4,00
70	10808	1	Grilletto	Déclencheur	Trigger	Drucktaster	6,50
71	10809	1	O-ring 4/1, perno valvola	Joint torique 4/1, soupape tige	O-ring 4/1, pin valve	O-ring 4/1 ventilstange	2,40
72	10810	1	Valvola ad ago per tempo di ritorno	Pointeau pour temps retour	Needle valve for return time	Einstellventil dauer linkslauf	7,00
73	10811	1	Vite superiore m6x16	Vis supérieur m6x16	Upper screw m6x16	Innensechskantschraube m6x16	2,40
74	10812	1	O-ring 4/2.2, perno valvola	Joint torique 4/2.2, soupape tige	O-ring 4/2.2, pin valve	O-ring 4/2.2 ventilstange	3,60
75	10813	1	O-ring 30/2	Joint torique 30/2	O-ring 30/2	O-ring 30/2	3,60
76	10814	1	Fondello serigrafato	Culot	Bottom	Bondenscheibe	20,00
77	10815	1	Valvola compressione	Soupape de compression	Compression valve	Druckfeder unter ventilstange	21,60
78	10816	1	Vite	Vis	Screw	Schraube	2,40
79	10817	1	Corpo	Corp	Body	körper	12,00
80	10822	1	O-ring	O-ring	O-ring	O-ring	3,00
81	10818	1	O-ring	O-ring	O-ring	O-ring	3,00
10819	1	1	Siringa	Seringue	Syringe	Spritze	9,00
10820	1	1	Bottiglia olio	Bouteille huile	Oil bottle	Öl Flasche	3,00
10821	1	1	Chiave brugola	Vis Allen	Allen screw	Innensechskantschlüssel	4,00

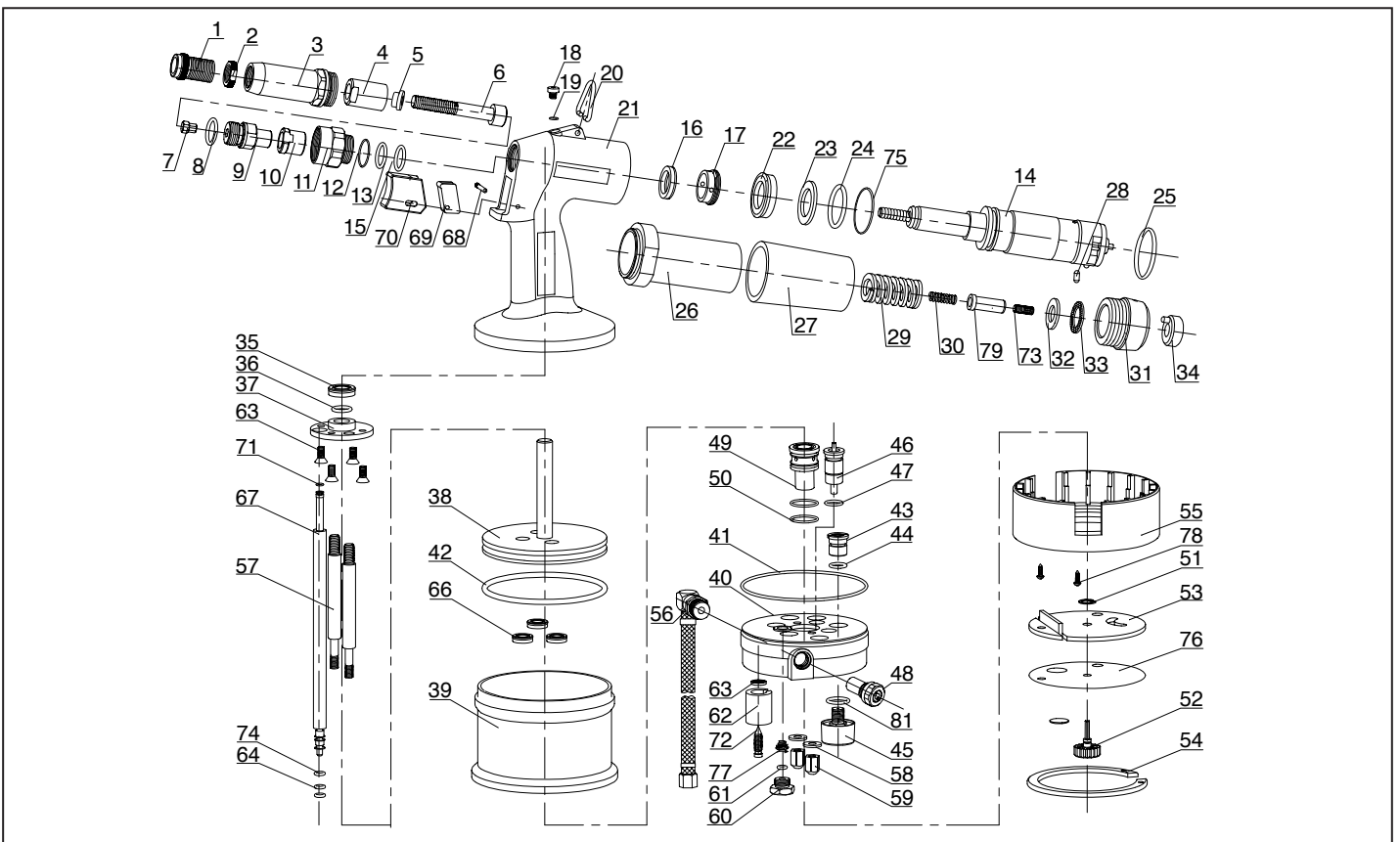



Rivettatrice oleopneumatica per inserti filettati M6÷M12.  
 Riveteuse oléopneumatique  
 Hydropneumatic tool for threaded inserts M6÷M12.  
 Öl-pneumatisches Werkzeug für Blindnietmuttern M6÷M12.

<b>PESO - WEIGHT - GEWICHT</b>	kg 2,5
--------------------------------	--------

M	ALLUMINIO ALUMINIUM ALUMINIUM	ACCIAIO STEEL STAHL	INOX INOX INOX
M6	•	•	•
M8	•	•	•
M10	•	•	•
M12	•	•	•

POS.	COD.	QT.	DESCRIZIONE	DENOMINATION	PARTS LIST	BEZEICHNUNG	€ cad.
1	10601M4	1	Tirante M4 a richiesta	Tirant M4	Tie rod M4	Gewindedorn M4	12,00
1	10601M5	1	Tirante M5 a richiesta	Tirant M5	Tie rod M5	Gewindedorn M5	12,00
1	10601M6	1	Tirante M6	Tirant M6	Tie rod M6	Gewindedorn M6	12,00
1	10601M8	1	Tirante M8	Tirant M8	Tie rod M8	Gewindedorn M8	12,00
1	10601M10	1	Tirante M10	Tirant M10	Tie rod M10	Gewindedorn M10	12,00
1	10601M12	1	Tirante M12	Tirant M12	Tie rod M12	Gewindedorn M12	12,00
2	10602M4	1	Testa M4	Tete M4	Head M4	Kopf M4	10,00
2	10602M5	1	Testa M5	Tete M5	Head M5	Kopf M5	10,00
2	10602M6	1	Testa M6	Tete M6	Head M6	Kopf M6	10,00
2	10602M8	1	Testa M8	Tete M8	Head M8	Kopf M8	10,00
2	10602M10	1	Testa M10	Tete M10	Head M10	Kopf M10	10,00
2	10602M12	1	Testa M12	Tete M12	Head M12	Kopf M12	10,00
3	10603	1	Ghiera testa	Ecrou tete	Nut	Deckungsring	3,80
4	10604	1	Cannotto	Canne	Nosepiece	Dusensträger	42,00
5	10605	1	Porta tirante	Porte tirant	connecting base	Drehkupplung	30,00
6	10606	1	Riduzione esagonale	Reducteur	Beschreibung	Untersetzung	6,00
7	10607	1	O ring	O ring	O ring	O ring	5,00
8	10608M10	1	Supporto M10	Support M10	Support M10	Lager M10	40,00
9	10609M10	1	Ghiera tirante M10	Ecrou tirant M10	Nut M10	Nutmutter M10	16,00
10	10610	1	Supporto cannotto	Support canne	Support	Lager	26,00
11	10611	1	O ring	O ring	O ring	O ring	2,50
14	10651M10	1	Pistone idraulico completo M10	Piston hydraulique complète M10	Complete hydraulic piston M10	Hydraulikkolben komplett M10	640,00
15	10652	1	O-ring 18/2.2, asta pistone idraulico	Joint torique 18/2.2, piston hydraulique tringle	O-ring 18/2.2, rod hydraulic piston	O-ring 18/2.2, hydraulische kolbenstange	4,00
16	10653	1	Sigillo ant. 26/18-6, asta pistone idraulico	Cachet frontale 26/18-6, piston hydraulique tringle	Front seal 26/18-6, rod hydraulic piston	Manschette 26/18-6, hydraul. kolbenstange	25,00
17	10654	1	Anello ammortizzatore, pistone idraulico	Anneau d'étaouffoir, piston hydraulique	Damper ring, hydraulic piston	Stoßring hydraulikkolben	28,60
18	10655	1	Vite tappo m 5x8	Vis taraudeuse M5x8	Tapping screw M5x8	Schraub Verschluß M5x8	2,00
19	10656	1	O-ring 4/1.5	Joint torique 4/1.5	O-ring 4/1.5	O-ring 4/1.5	4,80
20	10657	1	Gancio	Crochet	Hook	Haken	2,60
21	10658	1	Corpo idraulico	Corps hydraulique	Hydraulic body	Hydraulikgehäuse	380,00
22	10659	1	Sigillo anteriore 34/22-9.4, pistone idraulico	Cachet frontale 34/22-9.4, piston hydraulique	Front seal 34/22-9.4, hydraulic piston	Manschette 34/22-9.4 hydraulikkilben	25,00
23	10660	1	Anello di guida 34/22/2.5 teflon	Anneau avant 34/22/2.5 téflon	Leading ring 34/22/2.5 teflon	Führungsring 34/22/2.5 teflon	6,00
24	10661	1	O-ring 28/3, pistone idraulico	Joint torique 28/3, piston hydraulique	O-ring 28/3, hydraulic piston	O-ring 28/3, hydraulikkolben	6,00
25	10662	1	O-ring 36/2, tubo di avvitamento anteriore	Joint torique 36/2, tube de rotation frontale	O-ring 36/2, front-end spin tube	O-ring 36/2 hintere verschraubung	6,00
26	10663	1	Cannotto porta motore	Porte motor	Motor holding case	Motorhalter	36,00
27	10664	1	Protezione contenitore	Protection de corp	Body protectoin	Schutzscheibe	11,20
28	10665	1	Perno cilindrico 4,0x10	Goupille cylindrique 4,0x10	Cylindrical pin 4,0x10	Zylinderstifte 4,0x10	3,00
29	10666	1	Molla	Ressort	Spring	Feder	48,00
30	10667	1	Molla di compressione	Ressort de compression	Compression spring	Druckfeder	6,40
31	10669	1	Tubo di avvitamento anteriore	tube de rotation frontale	Front-end spin tube	Hintere verschraubung	45,00
32	10670	1	Anello per spina di compressione	Anneau pour spina de compression	Ring for compression pin	Ring für druckfeder	3,60
33	10671	1	Silenziatore	Silencieux	Silencer	Schalldämpfer	5,00
34	10672	1	Tasto di avvio	Poussoir start	Starting button	Drucktaster	2,40
35	10673	1	Sigillo ant. 22/12-7, asta pistone pneum.	Cachet frontal22/12-7, piston hydraulique tringle	Front end seal 22/12-7, rod pneum. piston	Manschette 22/12-7 pneum. kolbenstange	28,80
36	10674	1	O.R.	O.R.	O.R.	O.R.	5,60
37	10675	1	Ghiera inferiore	Ecrou à œil inferieur	Lower ring nut	Bodenring	24,20
38	10676	1	Pistone pneumatico	Piston pneumatique	Pneumatic piston	Pneumatikkolben	84,00
39	10677	1	Cilindro pneumatico	Cylindre pneumatique	Pneumatic cylinder	Pneumatikzylinder	164,00
40	10678	1	Ghiera di copertura	Ecrou à œil couverture	Covering ring nut	Verchlußplatte	86,50
41	10679	1	O-ring 14/2	Joint torique 14/2	O-ring 14/2	O-ring 14/2	12,00
42	10680	1	O-ring 89/4, pistone pneumatico	Joint torique 89/4, piston hydraulique	O-ring 89/4, pneumatic piston	O-ring 89/4 pneumatikkolben	12,00
43	10681	1	Attacco presa pressione	Pièce de fixation pression	Pressure fastening	Verbindungshülse für manometer	9,60
44	10682	1	O-ring 10/1.5	Joint torique 10/1.5	O-ring 10/1.5	O-ring 10/1.5	3,60
45	10683	1	Presa pressione	Accouplement pression	Pressure engagement	Manometer	30,00
46	10684	1	Indicatore livello olio	Indicateur niveau huile	Oil level indicator	Ölstandanzeiger	38,80
47	10685	1	O-ring 10/1.5	Joint torique 10/1.5	O-ring 10/1.5	O-ring 10/1.5	4,00
48	10686	1	Valvola rilievo pressione	Evaluation pression soupape	Valve pressure survey	Überdruckventil	29,00
49	10687	1	Valvola di regolazione pressione	Soupape régulation er pression	Regulation and pressure valve	Druckregelventig	25,00
50	10688	2	O-ring 18/1.5	Joint torique 18/1.5	O-ring 18/1.5	O-ring 18/1.5	4,00

POS.	COD.	QT.	DESCRIZIONE	DENOMINATION	PARTS LIST	BEZEICHNUNG	€ cad.
51	10689	1	Ghiera di ritenuta 6 din 471	Ecrou à cœil 6din 471	Ring nut 6 din 471	Sicherungsring 6 din 471	6,40
52	10690	1	Vite regolazione pressione	Poussoir régulation er pression	Regulation and pressure button	Einstellschraube druck	9,00
53	10691	1	Copertura	Couverture	Covering	Abschirmung	4,40
54	10692	1	Ghiera di ritenuta	Ecrou à cœil	Ring nut	Sicherungsring	6,40
55	10693	1	Ghiera inferiore	Ecrou à cœil inferieur	Lower ring nut	Bodenring	25,00
56	10694	1	Attacco connessione 90°	Tringlerie connexion 90°	90° connection linkage	Drehkupplung 90°	48,00
57	10695	2	Dado di connessione	Courseur de connexion	Connection nut	Führungsbolzen	16,00
58	10696	2	Rondella in rame per dado di connessione	Rondelle en cuivre pour curseur de connexion	Copper washer for connection nut	Kupfer scheibe	2,00
59	10697	2	Perno tappo m6 per dado di connessione	Tête tige m6 pour curseur de connexion	Pin cap m6 for connection nut	Überwurfmutter m6	3,00
60	10698	1	Perno valvola dado inferiore	Tige soupape curseur inferieur	Pin valve lower nut	Bolzen unter ventilstange	11,00
61	10699	1	O-ring 4/2, perno valvola	Joint torique 4/2, soupape tige	O-ring 4/2, pin valve	O-ring 4/2, ventilstange	3,60
62	10800	1	Valvola per valvola ad ago	Soupape pour pointeau	Valve for needle valve	Buchse für einstellventil	32,00
63	10801	1	Scarico	Décharge	Unloading	Schalldämpfer	4,00
64	10802	2	O-ring 4/2	Joint torique 4/2	O-ring 4/2	O-ring 4/2	3,60
65	10803	4	Vite	Vis	Screw	Schraube	6,40
66	10804	3	O-ring 10/2	Joint torique 10/2	O-ring 10/2	O-ring 10/2	3,60
67	10805	1	Perno valvola	Soupape tige	Pin valve	Ventilstange	38,20
68	10806	1	Perno cilindrico 3,0x20	Tige cylindrique 3,0x20	Cylindrical pin 3.0x20	Zylinderstifte 3,0x20	4,00
69	10807	1	Grilletto eccentrico	Déclencheur excentrique	Eccentric trigger	Exzentrische drucktaster	4,00
70	10808	1	Grilletto	Déclencheur	Trigger	Drucktaster	6,50
71	10809	1	O-ring 4/1, perno valvola	Joint torique 4/1, soupape tige	O-ring 4/1, pin valve	O-ring 4/1 ventilstange	2,40
72	10810	1	Valvola ad ago per tempo di ritorno	Pointeau pour temps retour	Needle valve for return time	Einstellventil dauer linkslauf	7,00
73	10811	1	Vite superiore m6x16	Vis supérieur m6x16	Upper screw m6x16	Innensechskantschraube m6x16	2,40
74	10812	1	O-ring 4/2,2, perno valvola	Joint torique 4/2,2, soupape tige	O-ring 4/2,2, pin valve	O-ring 4/2,2 ventilstange	3,60
75	10813	1	O-ring 30/2	Joint torique 30/2	O-ring 30/2	O-ring 30/2	3,60
76	10814	1	Fondello serigrafato	Culot	Bottom	Bondenscheibe	20,00
77	10815	1	Valvola compressione	Soupape de compression	Compression valve	Druckfeder unter ventilstange	21,60
78	10816	1	Vite	Vis	Screw	Schraube	2,40
79	10817	1	Corpo	Corp	Body	körper	12,00
80	10822	1	O-ring	O-ring	O-ring	O-ring	3,00
81	10818	1	O-ring	O-ring	O-ring	O-ring	3,00
10819	1	Siringa	Seringue	Syringe	Spritze		9,00
10820	1	Bottiglia olio	Bouteille huile	Oil bottle	Öl Flasche		3,00
10821	1	Chiave brugola	Vis Allen	Allen screw	Innensechskantschlüssel		4,00

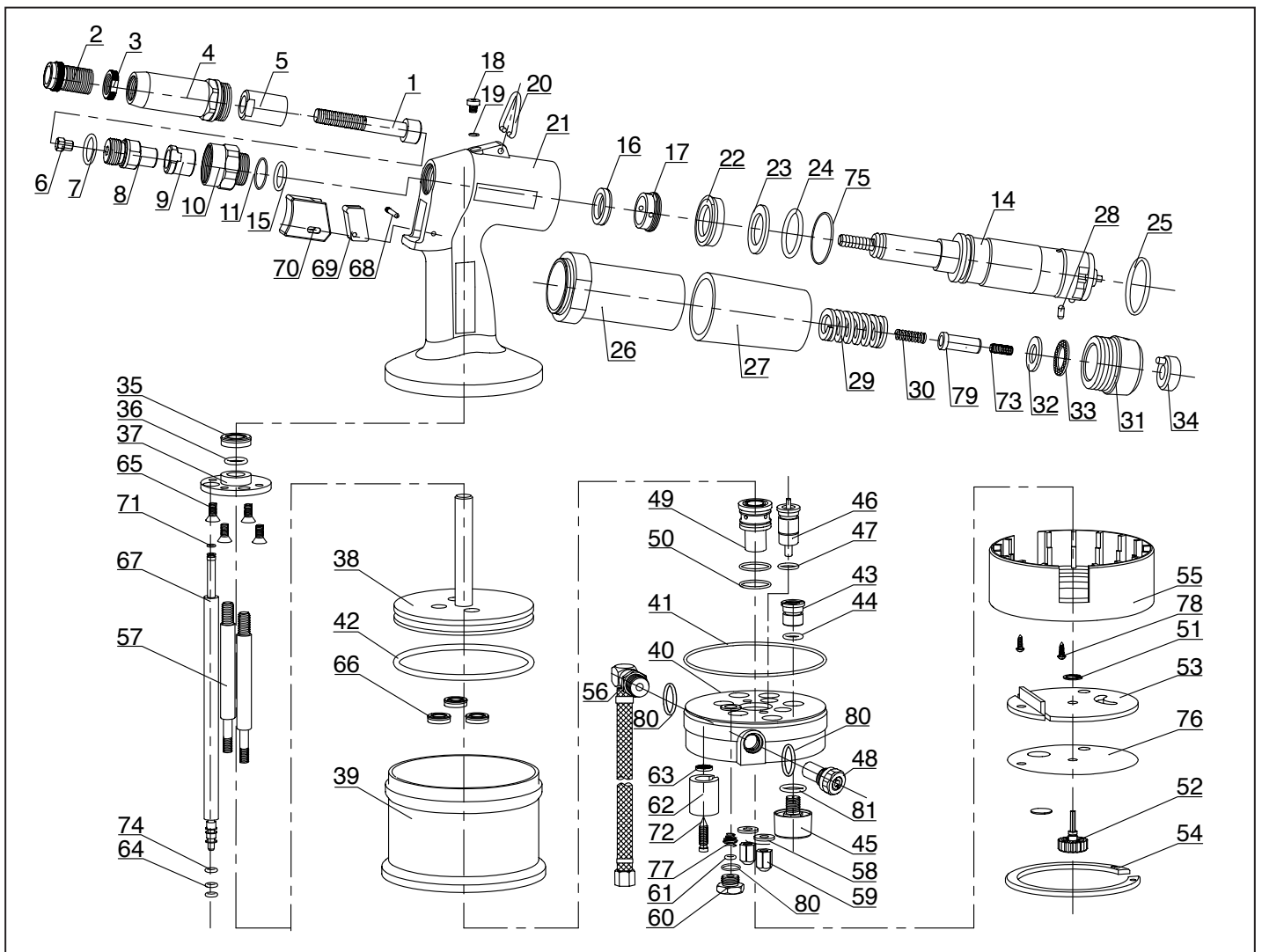



Rivettatrice oleopneumatica per inserti filettati M6÷M12.

Riveteuse oléopneumatique

Hypdropneumatic tool for threaded inserts M6÷M12.

Öl-pneumatisches Werkzeug für Blindnietmuttern M6÷M12.

**PESO - WEIGHT - GEWICHT**

kg 2,5

M	ALLUMINIO ALUMINIUM ALUMINIUM	ACCIAIO STEEL STAHL	INOX INOX INOX
M6	•	•	•
M8	•	•	•
M10	•	•	•
M12	•	•	•

POS.	COD.	QT.	DESCRIZIONE	DENOMINATION	PARTS LIST	BEZEICHNUNG	€ cad.
1	168110M4	1	Testa M4	Tête M4	Head M4	Kopf M5	8,50
1	168110M5	1	Testa M5	Tête M5	Head M5	Kopf M5	8,50
1	168110M6	1	Testa M6	Tête M6	Head M6	Kopf M6	8,50
1	168110M8	1	Testa M8	Tête M8	Head M8	Kopf M8	8,50
1	168110M10	1	Testa M10	Tête M10	Head M10	Kopf M10	8,50
1	168110M12	1	Testa M12	Tête M12	Head M12	Kopf M12	8,50
2	168111	1	Ghiera	Embout	Nut	Schraubenmutter	6,80
3	168112	1	Cannotto	Canne	Nosepiece	Dusentrager	66,00
4	168114	1	Porta tirante	Porte tirant	Connection base	Drehkupplung	22,00
5	168116M4	1	Adattatore M4	Adaptateur M4	Adaptor M4	Ansatz M4	4,20
5	168116M5	1	Adattatore M5	Adaptateur M5	Adaptor M5	Ansatz M5	4,20
5	168116M6	1	Adattatore M6	Adaptateur M6	Adaptor M6	Ansatz M6	4,20
5	168116M8	1	Adattatore M8	Adaptateur M8	Adaptor M8	Ansatz M8	4,20
5	168116M10	1	Adattatore M10	Adaptateur M10	Adaptor M10	Ansatz M10	4,20
6	168125M4	1	Tirante M4	Tirant M4	Tie rod M4	Gewindedorn M4	4,80
6	168125M5	1	Tirante M5	Tirant M5	Tie rod M5	Gewindedorn M5	4,80
6	168125M6	1	Tirante M6	Tirant M6	Tie rod M6	Gewindedorn M6	4,80
6	168125M8	1	Tirante M8	Tirant M8	Tie rod M8	Gewindedorn M8	4,80
6	168125M10	1	Tirante M10	Tirant M10	Tie rod M10	Gewindedorn M10	4,80
6	168125M12	1	Tirante M12	Tirant M12	Tie rod M12	Gewindedorn M12	4,80
7	168130M4	1	Riduzione esagonale M4	Reducteur M4	Hexagonal reduction M4	Sechskantreduzier M4	4,00
7	168130M5	1	Riduzione esagonale M5	Reducteur M5	Hexagonal reduction M5	Sechskantreduzier M5	4,00
7	168130M6	1	Riduzione esagonale M6	Reducteur M6	Hexagonal reduction M6	Sechskantreduzier M6	4,00
7	168130M8	1	Riduzione esagonale M8	Reducteur M8	Hexagonal reduction M8	Sechskantreduzier M8	4,00
7	168130M10	1	Riduzione esagonale M10	Reducteur M10	Hexagonal reduction M10	Sechskantreduzier M10	4,00
7	168130M12	1	Riduzione esagonale M12	Reducteur M12	Hexagonal reduction M12	Sechskantreduzier M12	4,00
7	10607	1	O ring	O ring	O ring	O ring	5,00
8	10608M10	1	Supporto M10	Support M10	Support M10	Lager M10	40,00
9	10609M10	1	Ghiera tirante M10	Ecrou tirant M10	Nut M10	Nutmutter M10	16,00
10	10610	1	Supporto canotto	Support canne	Support	Lager	26,00
11	10611	1	O ring	O ring	O ring	O ring	2,50
14	10651M10	1	Pistone idraulico completo M10	Piston hydraulique complète M10	Complete hydraulic piston M10	Hydraulikkolben komplett M10	640,00
15	10652	1	O-ring 18/2,2, asta pistone idraulico	Joint torique 18/2,2, piston hydraulique tringle	O-ring 18/2,2, rod hydraulic piston	O-ring 18/2,2, hydraulische kolbenstange	4,00
16	10653	1	Sigillo ant. 26/18-6, asta pistone idraulico	Cachet frontale 26/18-6, piston hydraulique tringle	Front seal 26/18-6, rod hydraulic piston	Manschette 26/18-6, hydraul. kolbenstange	25,00
17	10654	1	Anello ammortizzatore, pistone idraulico	Anneau d'étaffoir, piston hydraulique	Damper ring, hydraulic piston	Stoßring hydraulikkolben	28,60
18	10655	1	Vite tappo m 5x8	Vis taraudeuse M5x8	Tapping screw M5x8	Schraub Verschluß M5x8	2,00
19	10656	1	O-ring 4/1.5	Joint torique 4/1.5	O-ring 4/1.5	O-ring 4/1.5	4,80
20	10657	1	Gancio	Crochet	Hook	Haken	2,60
21A	10658N	1	Corpo idraulico	Corps hydraulique	Hydraulic body	Hydraulikgehäuse	380,00
22	10659	1	Sigillo anteriore 34/22-9.4, pistone idraulico	Cachet frontale 34/22-9.4, piston hydraulique	Front seal 34/22-9.4, hydraulic piston	Manschette 34/22-9.4 hydraulikkolben	25,00
23	10660	1	Anello di guida 34/22/2.5 teflon	Anneau avant 34/22/2.5 téflon	Leading ring 34/22/2.5 teflon	Führungsring 34/22/2.5 teflon	6,00
24	10661	1	O-ring 28/3, pistone idraulico	Joint torique 28/3, piston hydraulique	O-ring 28/3, hydraulic piston	O-ring 28/3, hydraulikkolben	6,00
25	10662	1	O-ring 36/2, tubo di avvitamento anteriore	Joint torique 36/2, tube de rotation frontale	O-ring 36/2, front-end spin tube	O-ring 36/2 hintere verschraubung	6,00
26	10663	1	Cannotto porta motore	Porte motor	Motor holding case	Motorhalter	36,00
27	10664	1	Protezione contenitore	Protection de corp	Body protectoin	Schutzscheibe	11,20
28	10665	1	Perno cilindrico 4,0x10	Goupille cylindrique 4,0x10	Cylindrical pin 4,0x10	Zylinderstifte 4,0x10	3,00
29	10666	1	Molla	Ressort	Spring	Feder	48,00
30	10667	1	Molla di compressione	Ressort de compression	Compression spring	Druckfeder	6,40
31	10669	1	Tubo di avvitamento anteriore	tube de rotation frontale	Front-end spin tube	Hintere verschraubung	45,00
32	10670	1	Anello per spina di compressione	Anneau pour Goupille de compression	Ring for compression pin	Ring für druckfeder	3,60
33	10671	1	Silenziatore	Silencieux	Silencer	Schalldämpfer	5,00
34	10672	1	Tasto di avvio	Poussoir start	Starting button	Drucktaster	2,40
35A	10673N	1	Sigillo anteriore	Cachet frontal	Front end seal	Manschette	5,00
36A	10674N	1	Pistoncino	Piston	Piston	Piston	28,00
37A	10675N	1	Guarnizione	O.R.	O.R.	O.R.	5,00
38-1	10676-1	1	Base pistone	Base piston	Piston base	Base Piston	38,00
38-2	10676-2	1	Pistone	Piston	Piston	Piston	32,00
38-3	10676-3	1	Vite	Vis	Screw	Schraube	2,00
38-4	10676-4	1	O.R.	O.R.	O.R.	O.R.	6,00
39	10677	1	Cilindro	Cylindre	Cylinder	Zylinder	164,00

POS.	COD.	QT.	DESCRIZIONE	DENOMINATION	PARTS LIST	BEZEICHNUNG	€ cad.
40	10678	1	Ghiera di copertura	Ecrou à ceil couverte	Covering ring nut	Verchlußplatte	86,50
41	10679	1	O-ring 14/2	Joint torique 14/2	O-ring 14/2	O-ring 14/2	12,00
42	10680	1	O-ring 89/4, pistone pneumatico	Joint torique 89/4, piston hydraulique	O-ring 89/4, pneumatic piston	O-ring 89/4 pneumatikkolben	12,00
43	10681	1	Attacco presa pressione	Pièce de fixation pression	Pressure fastening	Verbindungshülse für manometer	9,60
44	10682	1	O-ring 10/1.5	Joint torique 10/1.5	O-ring 10/1.5	O-ring 10/1.5	3,60
45	10683	1	Presa pressione	Accouplement pression	Pressure engagement	Manometer	30,00
46	10684	1	Indicatore livello olio	Indicateur niveau huile	Oil level indicator	Ölstandanzeiger	38,80
47	10685	1	O-ring 10/1.5	Joint torique 10/1.5	O-ring 10/1.5	O-ring 10/1.5	4,00
48	10686	1	Valvola rilievo pressione	Evaluation pression soupape	Valve pressure survey	Überdruckventil	29,00
49	10687	1	Valvola di regolazione pressione	Soupape régulation er pression	Regulation and pressure valve	Druckregelventiq	25,00
50	10688	2	O-ring 18/1.5	Joint torique 18/1.5	O-ring 18/1.5	O-ring 18/1.5	4,00
51	10689	1	Ghiera di ritenuta 6 din 471	Ecrou à ceil 6din 471	Ring nut 6 din 471	Sicherungsring 6 din 471	6,40
52	10690	1	Vite regolazione pressione	Poussoir régulation er pression	Regulation and pressure button	Einstellschraube druck	9,00
53	10691	1	Copertura	Couverture	Covering	Abschirmung	4,40
54	10692	1	Ghiera di ritenuta	Ecrou à ceil	Ring nut	Sicherungsring	6,40
55	10693	1	Ghiera inferiore	Ecrou à ceil inferieur	Lower ring nut	Bodenring	25,00
56	10694	1	Attacco connessione 90°	Tringlerie connexion 90°	90° connection linkage	Drehkupplung 90°	48,00
57	10695	2	Dado di connessione	Curseur de connexion	Connection nut	Führungsbolzen	16,00
58	10696	2	Rondella in rame per dado di connessione	Rondelle en cuivre pour curseur de connexion	Copper washer for connection nut	Kupfer scheibe	2,00
59	10697	2	Perno tappo m6 per dado di connessione	Tête tige m6 pour curseur de connexion	Pin cap m6 for connection nut	Überwurfmutter m6	3,00
60	10698	1	Perno valvola dado inferiore	Tige soupape curseur inferieur	Pin valve lower nut	Bolzen unter ventilstange	11,00
61	10699	1	O-ring 4/2, perno valvola	Joint torique 4/2, soupape tige	O-ring 4/2, pin valve	O-ring 4/2, ventilstange	3,60
62	10800	1	Valvola per valvola ad ago	Soupape pour pointeau	Valve for needle valve	Buchse für einstellventil	32,00
63A	10801	1	Vite	Vis	Screw	Schraube	4,00
64	10802	2	O-ring 4/2	Joint torique 4/2	O-ring 4/2	O-ring 4/2	3,60
65A	10803	1	Vite	Vis	Screw	Schraube	6,40
66	10804	3	O-ring 10/2	Joint torique 10/2	O-ring 10/2	O-ring 10/2	3,60
67	10805	1	Perno valvola	Soupape tige	Pin valve	Ventilstange	38,20
68	10806	1	Perno cilindrico 3,0x20	Tige cylindrique 3,0x20	Cylindrical pin 3,0x20	Zylinderstifte 3,0x20	4,00
69	10807	1	Grilletto eccentrico	Déclencheur excentrique	Eccentric trigger	Exzentrische drucktaster	4,00
70	10808	1	Grilletto	Déclencheur	Trigger	Drucktaster	6,50
71	10809	1	O-ring 4/1, perno valvola	Joint torique 4/1, soupape tige	O-ring 4/1, pin valve	O-ring 4/1 ventilstange	2,40
72	10810	1	Valvola ad ago per tempo di ritorno	Pointeau pour temps retour	Needle valve for return time	Einstellventil dauer linkslauf	7,00
73	10811	1	Vite superiore m6x16	Vis supérieur m6x16	Upper screw m6x16	Innensechskantschraube m6x16	2,40
74	10812	1	O-ring 4/2.2, perno valvola	Joint torique 4/2.2, soupape tige	O-ring 4/2.2, pin valve	O-ring 4/2.2 ventilstange	3,60
75	10813	1	O-ring 30/2	Joint torique 30/2	O-ring 30/2	O-ring 30/2	3,60
76	10814	1	Fondello serigrafato	Culot	Bottom	Bondenscheibe	20,00
77	10815	1	Valvola compressione	Soupape de compression	Compression valve	Druckfeder unter ventilstange	21,60
78	10816	2	Vite	Vis	Screw	Schraube	2,40
79	10817	1	Corpo	Corp	Body	körper	12,00
80	10822	1	O-ring	O-ring	O-ring	O-ring	3,00
81	10818	1	O-ring	O-ring	O-ring	O-ring	3,00
10819	1	Siringa	Seringue	Syringe	Spritze	9,00	
10820	1	Bottiglia olio	Bouteille huile	Oil bottle	Öl Flasche	3,00	
10821	1	Chiave brugola	Vis Allen	Allen screw	Innensechskantschlüssel	4,00	

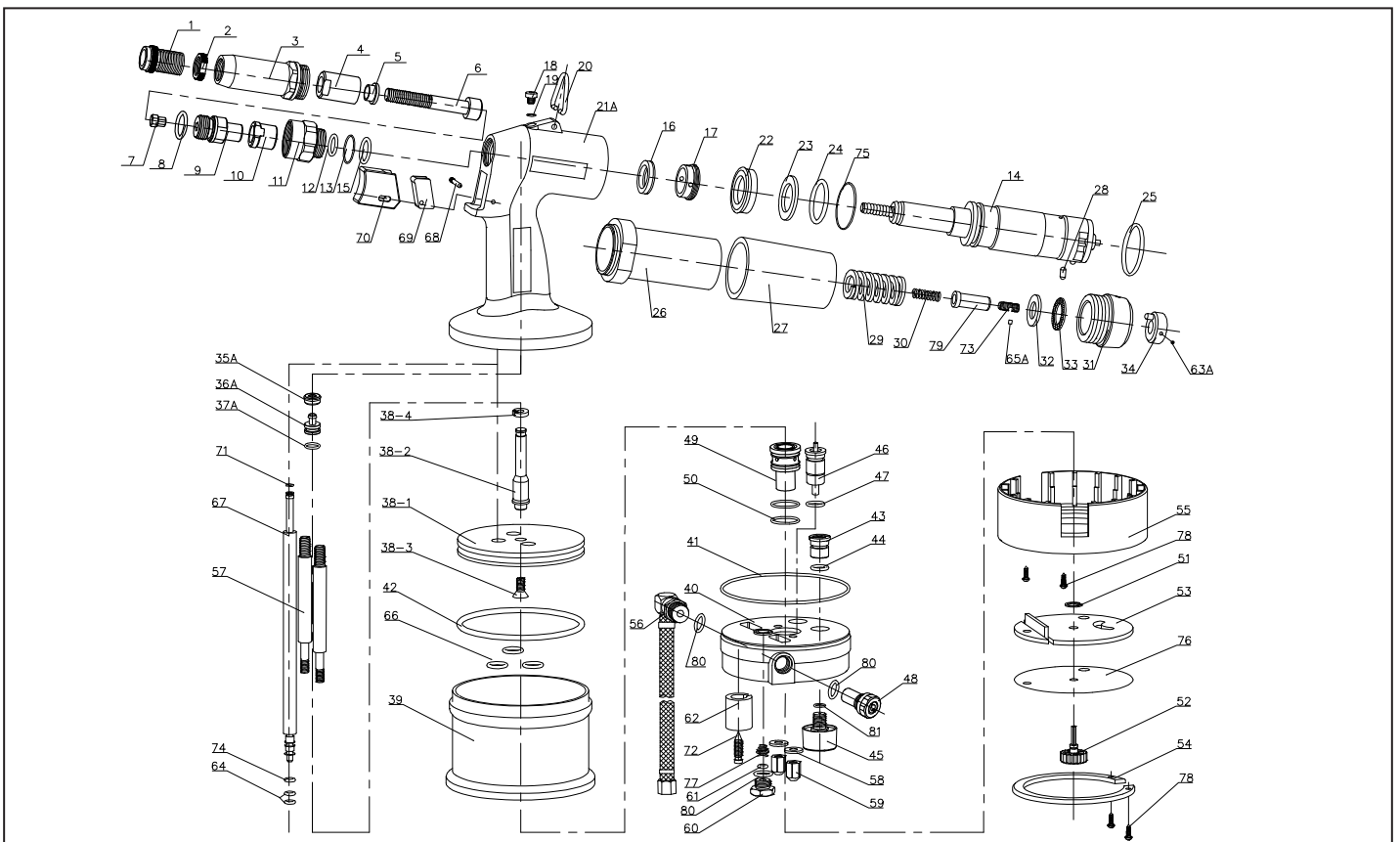



Rivettatrice elettrica in valigetta completa di un caricabatteria e **due batterie al litio** (18 V / 2,0 Ah)

Case containing one tool, one battery charger and **two lithium battery**

Kunststoffkoffer mit 1 Nietgerät, 1 Ladegerät und **2 Lithium Batterien**

<b>PESO - WEIGHT - GEWICHT</b>	kg 1,90
<b>CORSA - STROKE</b>	mm 21,00
<b>FORZA - FORCE</b>	N. 10.000

Ø	ALLUMINIO ALUMINIUM ALUMINIUM	RAME COPPER KUPFER	ACCIAIO STEEL STAHL	INOX INOX INOX
3	•	•	•	•
3,2	•	•	•	•
4	•	•	•	•
4,8/5	•	•	•	•

Pos	Codice	QT.	DESCRIZIONE	DENOMINATION	PARTS LIST
1	35000 001	1	Guscio sinistro	Coquille gauche	Housing left
3	35000 002	1	Grilletto	Levier	Trigger switch
4	55000 001	1	Molla	Ressort	Spring
5	15000 001	1	Scheda di cablaggio	Electronic assembly	Electronic assembly
7	35000 003	2	Viti	Vis	Screw
8	15000 002	1	Gruppo trazione	Traction	Gear box
10	35000 004	1	Tubo in plastica	Tuyau	Plastic tube
11	25000 001	1	Contenitore chiodi	Bol pour clous	Naill container
12	35000 005	1	Guscio destro	Coquille droite	Housing right
14	35000 006	1	Gancio	Crochet	Hook
15	25000 002	1	Motore completo	Moteur complet	Engine complete
17	35000 007	1	Raccordo	Clip	Clip
18	55000 002	2	Viti	Vis	Screw
19	55000 003	8	Viti	Vis	Screw
20	15000 020	1	Batteria 18 V/2.0 Ah	Batterie	Battery
22	15000 003	1	Carica batteria 220 V	Chargeur	Battery charger
23	55000 023	1	Supporto magnetico	Support magnetique	Magnet holder
24	55000 004	2	Viti con rondella	Vis	Screw
27	15000 004	1	O.r distanziale	O.r espaceur	Spacer
28	55000 028	1	Molla premente	Ressort	Spring
29	15000 005	1	Apri morsetti	Ouvre-étaux	Jaws opener
30	15000 006	3	Set di n. 3 morsetti	Set n. 3 étaux	Set n 3 jaws
32	55000 032	1	O.R.	O.R.	O.R.
33	15000 008	1	Cannotto	Tube porte embout	Head carrying nosepiece
35	15000 035	1	Ugello per rivetto Ø 3 - 3,2 mm	Embout Ø 3 - 3,2 mm	Nosepiece Ø 3 - 3,2 mm
36	15000 010	1	Ugello per rivetto Ø 4,0 mm	Embout Ø 4,0 mm	Nosepiece Ø 4,0 mm
37	16000 004	1	Ugello per rivetto Ø 4,8 mm	Embout Ø 4,8 mm	Nosepiece Ø 4,8 mm
40	15000 040	1	Raccordo	Raccord	Connector
41	15000 041	1	Molla	Ressort	Spring
42	15000 042	1	Anello tenuta	Bauge	Ring
43	15000 043	1	Adattatore	Raccord	Connector
44	15000 044	1	Cono porta morsetti	Cone porte étaux	Cone holding jaws

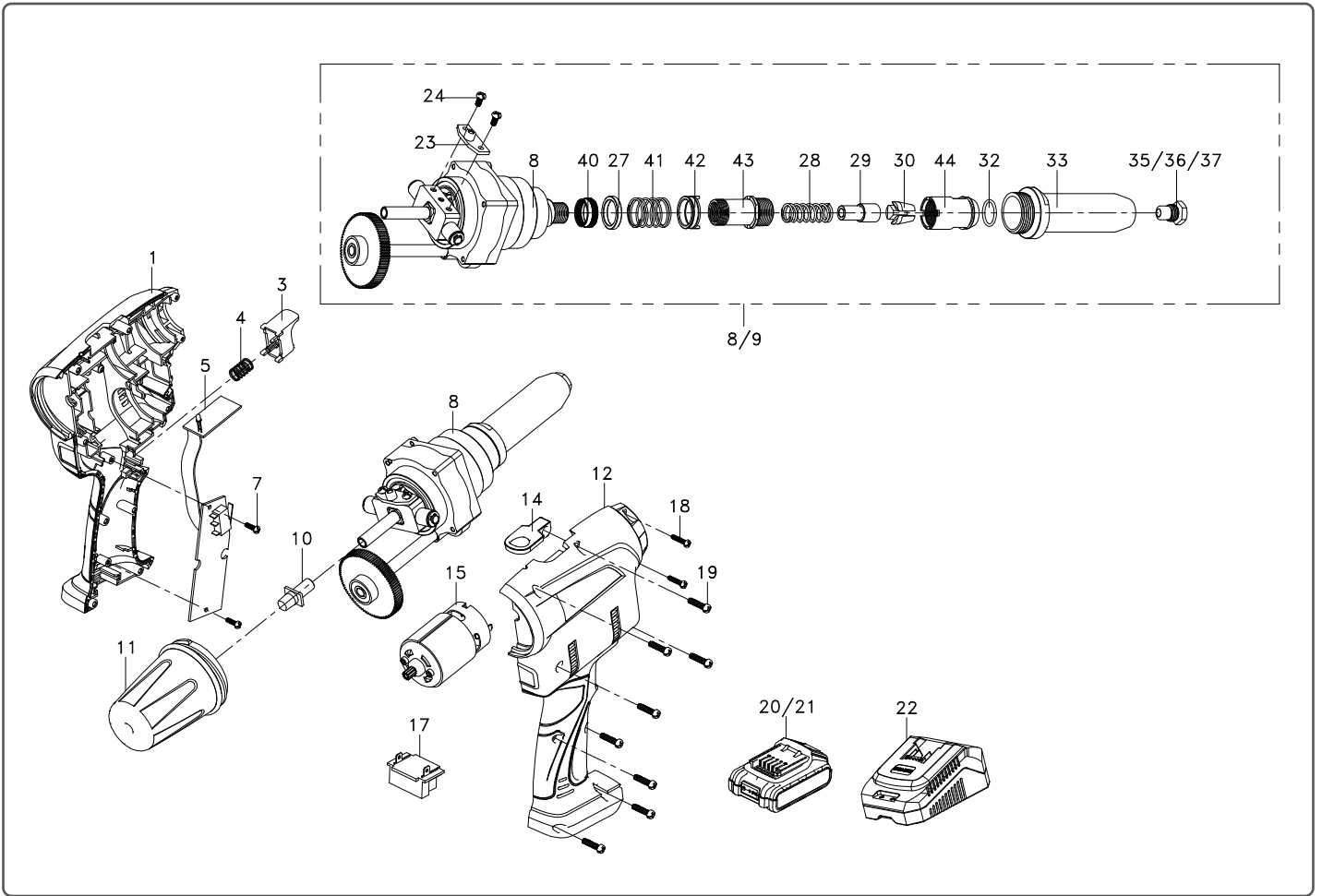



Rivettatrice elettrica in valigetta completa di un caricabatteria e **due batterie al litio** (18 V / 2,0 Ah)

Case containing one tool, one battery charger and **two lithium battery**

Kunststoffkoffer mit 1 Nietgerät, 1 Ladegerät und **2 Lithium Batterien**

<b>PESO - WEIGHT - GEWICHT</b>	kg 1,90
<b>CORSA - STROKE</b>	mm 30,00
<b>FORZA - FORCE</b>	N. 20.000

Ø	ALLUMINIO ALUMINIUM ALUMINIUM	RAME COPPER KUPFER	ACCIAIO STEEL STAHL	INOX INOX INOX
4	•	•	•	•
4,8-5	•	•	•	•
6,4	•	•	•	•
7,8	•			

Pos	Codice	QT.	DESCRIZIONE	DENOMINATION	PARTS LIST
2	36000 001	1	Guscio sinistro	Coquille gauche	Housing left
3	35000 002	1	Grilletto	Levier	Trigger switch
4	55000 001	1	Molla	Ressort	Spring
6	16000 001	1	Scheda di cablaggio	Electronic assembly	Electronic assembly
7	35000 003	2	Viti	Vis	Screw
9	16000 002	1	Gruppo trazione	Traction	Gear box
10	35000 004	1	Tube in plastica	Tuyau	Plastic tube
11	25000 001	1	Contenitore chiodi	Bol pour clous	Nail container
13	36000 005	1	Guscio destro	Coquille droite	Housing right
14	35000 006	1	Gancio	Crochet	Hook
16	26000 002	1	Motore completo	Moteur complet	Engine complete
17	35000 007	1	Raccordo	Clip	Clip
18	55000 002	2	Viti	Vis	Screw
19	55000 003	8	Viti	Vis	Screw
20	15000 020	1	Batteria 18 V/2.0 Ah	Batterie	Battery
22	15000 003	1	Carica batteria 220 V	Chargeur	Battery charger
23	55000 023	1	Supporto magnetico	Support magnetic	Magnet holder
24	55000 004	2	Viti con rondella	Vis	Screw
27	15000 004	1	O.r distanziale	O.r espaceur	Spacer
28	55000 028	1	Molla premente	Ressort	Spring
29	15000 005	1	Apri morsetti	Ouvre-étaux	Jaws opener
30	15000 006	3	Set di n. 3 morsetti	Set n. 3 étaux	Set n 3 jaws
31	15000 007	1	Cono porta morsetti	Cone porte étaux	Cone holding jaws
32	55000 032	1	O.R.	O.R.	O.R.
33	15000 008	1	Cannotto	Tube porte embout	Head carrying nosepiece
36	15000 010	1	Ugello per rivetto Ø 4,0 mm	Embout Ø 4,0 mm	Nosepiece Ø 4,0 mm
37	16000 004	1	Ugello per rivetto Ø 4,8 mm	Embout Ø 4,8 mm	Nosepiece Ø 4,8 mm
38	16000 005	1	Ugello per rivetto Ø 6 - 7,8 mm	Embout Ø 6 - 7,8 mm	Nosepiece Ø 6 - 7,8 mm
40	15000 040	1	Raccordo	Raccord	Connector
41	15000 041	1	Molla	Ressort	Spring
42	15000 042	1	Anello tenuta	Bauge	Ring
43	15000 043	1	Adattatore	Raccord	Connector





Rivettatrice elettrica per inserti filettati in valigetta completa di un caricabatteria e **due batterie al litio** (18 V / 2,0 Ah)

Case containing one tool, one battery charger and **two lithium battery**

<b>PESO - WEIGHT - GEWICHT</b>	kg 2,30
<b>CORSA - STROKE</b>	mm 7,00
<b>FORZA - FORCE</b>	N. 22.000

M	ALLUMINIO ALUMINIUM ALUMINIUM	ACCIAIO STEEL STAHL	INOX INOX INOX
M 4	•	•	•
M 5	•	•	•
M 6	•	•	•
M 8	•	•	•
M 10	•	•	NO

Pos	Codice	QT.	DESCRIZIONE	DENOMINATION	PARTS LIST
1	38000 001	1	Guscio sinistro	Coquille gauche	Housing left
2	35000 002	1	Grilletto	Levier	Trigger switch
3	55000 001	1	Molla	Ressort	Spring
4	18000 001	1	Scheda di cablaggio	Electronic assembly	Electronic assembly
5	35000 003	2	Vite	Vis	Screw
6	18000 002	1	Gruppo trazione	Traction	Gear box
7	18000 003	1	Gruppo frizione	Embrayage	Clutch
8	28000 001	1	Contenitore	Collector	Collector
9	38000 002	1	Guscio destro	Coquille droite	Housing right
10	35000 006	1	Gancio	Crochet	Hook
11	25000 002	1	Motore completo	Moteur complet	Engine complete
12	35000 007	1	Raccordo	Clip	Clip
13	55000 002	2	Viti	Vis	Screw
14	55000 003	8	Viti	Vis	Screw
15	15000 020	1	Batteria 18 V/2.0 Ah	Batterie	Battery
16	15000 003	1	Carica batteria 220 V	Chargeur	Battery charger
17	15000 011	1	Ingranaggio	Rapport	Gear
18	55000 005	2	Vite con rondella	Vis	Screw whit washer
34	18000 008	1	Asta	Axe	Main shaft
35	55000 023	1	Supporto magnetico	Support magnetic	Magnet holder
36	55000 004	2	Vite con rondella	Vis	Screw
38	18000 010	1	Anello tenuta	Bauge	Ring
39	58000 010	2	Rondella	Rondelle	Washer
40	58000 011	1	Anello di sicurezza	Bauge	Circlips
41	18000011	1	Supporto filettato	Support	Inner sleeve
42	58000 012	1	Rondella	Rondelle	Washer
43	18000 012	1	Cono filettato	Cone	Sleeve
44	18000 013	1	Adattatore	Raccord	Connector
45	58000 013	1	Molla	Ressort	Spring
46	58000 014	1	Vite	Vis	Screw
47	58000 015	1	Rondella elastica	Rondelle	Washer
48	58000 016	1	Rondella	Rondelle	Washer
49	58000 017	1	Rondella	Rondelle	Washer
50	58000 018	1	Rondella	Rondelle	Washer
51	58000 019	1	Molla	Ressort	Spring

Pos	Codice	QT.	DESCRIZIONE	DENOMINATION	PARTS LIST
52	18000 014	1	Porta tirante	Cone	Sleeve
53	58000 020	1	Clip	Clip	Clip
54	18000 015	1	Supporto filettato	Support	Inner sleeve
55	18000 016	1	Controdado E	Ecru	Nut
56	18000 017	1	Ghiera di regolazione	Virole	Sleeve
57	18000 018	1	Controdado C	Ecru	Nut
58	18000 020	1	Tirante M4	Tirant M4	Tie rod M4
59	18000 021	1	Tirante M5	Tirant M5	Tie rod M5
60	18000 022	1	Tirante M6	Tirant M6	Tie rod M6
61	18000 023	1	Tirante M8	Tirant M8	Tie rod M8
62	18000 024	1	Tirante M10	Tirant M10	Tie rod M10
63	18001 030	1	Testa M4	Tête M4	Head M4
64	18002 031	1	Testa M5	Tête M5	Head M5
65	18003 032	1	Testa M6	Tête M6	Head M6
66	18004 033	1	Testa M8	Tête M8	Head M8
67	18005 034	1	Testa M10	Tête M10	Head M10

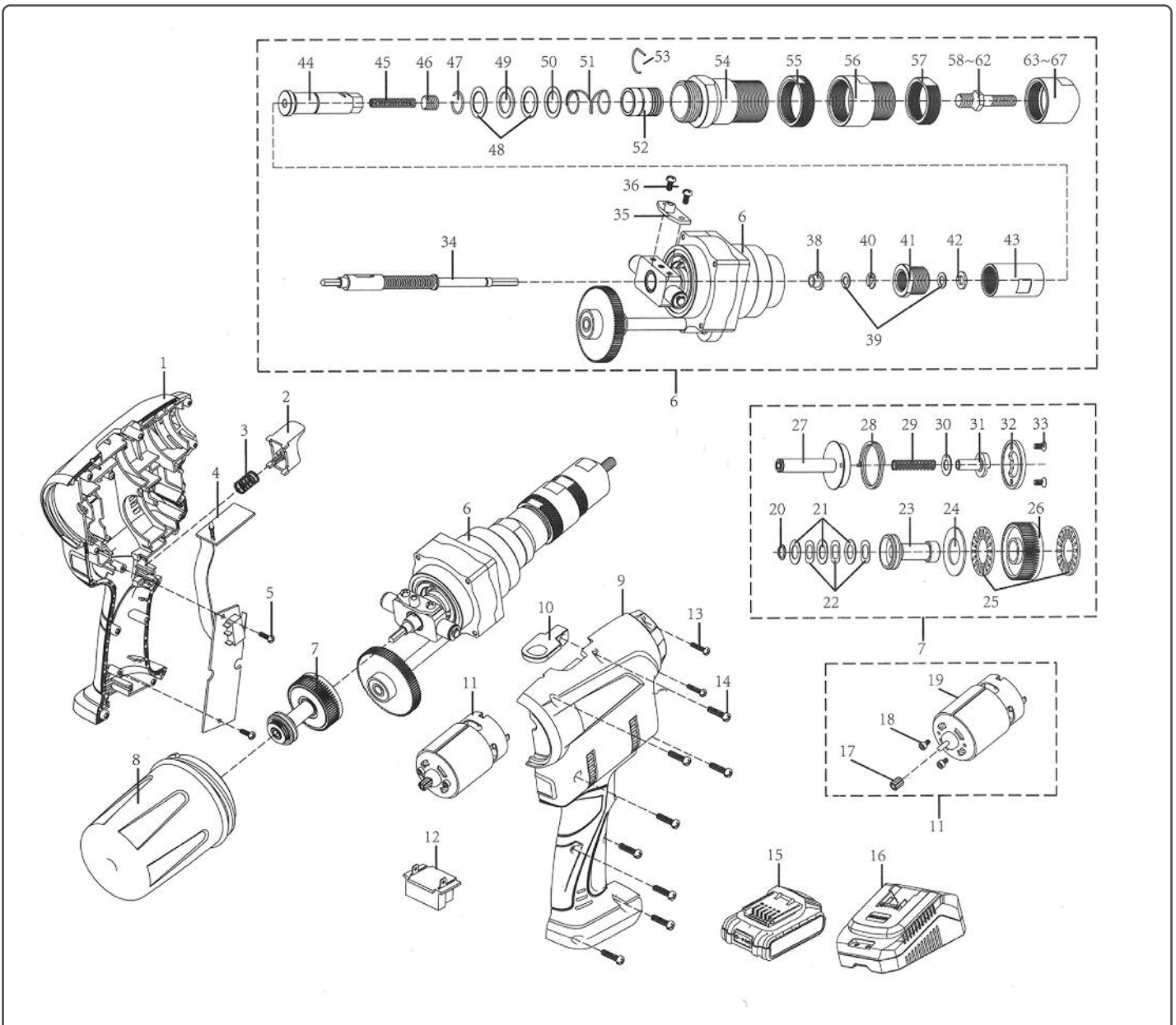





# SACTO

SACTO srl - Via C. Porta 61 - 20831 Seregno (MB) Italia  
Telefono +39 0362 232307 - Telefax +39 0362 235842  
[www.sacto.it](http://www.sacto.it) - [info@sacto.it](mailto:info@sacto.it)